

REPUBLIQUE DU CAMEROUN
Paix-Travail-Patrie

MINISTRE DE LA DÉCENTRALISATION
ET DU DEVELOPPEMENT LOCAL

DELEGATION REGIONALE DU NORD OUEST

DEPARTEMENT DE NGOKETUNJIA

ARRONDISSEMENT DE NDOP

COMMUNE DE NDOP

SERVICE DE PASSATION DES
MARCHES PUBLICS

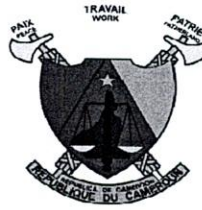

REPUBLIC OF CAMEROON
Peace-Work-Fatherland

MINISTRY OF DECENTRALISATION
AND LOCAL DEVELOPMENT

NORTH WEST REGIONAL DELEGATION

NGOKETUNJIA DIVISION

NDOP SUB-DIVISION

NDOP COUNCIL

SERVICE FOR THE AWARD OF PUBLIC
CONTRACTS

NDOP COUNCIL INTERNAL TENDERS' BOARD

TENDER FILE

OPEN NATIONAL INVITATION TO TENDER BY EMERGENCY PROCEDURE

N° ¹⁰ /ONIT/MINDDEVEL/NC/NCITB/BIPMINTP/ 2026 OF ^{08 AVR 2026} FOR THE
CONSTRUCTION WORKS FOR A PERMANENT 6 M REINFORCED CONCRETE
BRIDGE IN THE HAUSA QUARTER, INCLUDING THE CONSTRUCTION OF A 2 M ×
2 M BOX CULVERT ALONG THE BAMUNKA-NDOP ROAD SECTION;
CONSTRUCTION WORKS FOR A PERMANENT 7 M LINEAR REINFORCED
CONCRETE BRIDGE OVER THE UPPER KAKE RIVER IN BAMUNKA VILLAGE,
ALONG THE BAMUNKA-NDOP ROAD; AND CONSTRUCTION WORKS FOR A
PERMANENT 8 M LINEAR REINFORCED CONCRETE BRIDGE OVER THE UPPER
MUNJONG RIVER ALONG THE BAMUNKA-NDOP ROAD SECTION IN NDOP
MUNICIPALITY, NGOKETUNJIA DIVISION IN NORTH WEST REGION.

PROJECT OWNER: THE MAYOR - NDOP COUNCIL

FINANCING : PIB MINTP 2026
BUDGET HEAD: 60363702320000030451
RECORD N° : 523411

FINANCIAL YEAR 2026

TABLE OF CONTENTS

- Document No. 1: Tender Notice
- Document No. 2: General Regulations of the Invitation to Tender
- Document No. 3: Special Regulations of the Invitation to Tender
- Document No. 4: Special Administrative Conditions
- Document No. 5: Special Technical Conditions
- Document No. 6: Schedule of Unit Prices
- Document No. 7: Bill of Quantities and Estimates
- Document No. 8: The Sub-Detail of Prices
- Document No. 9: Model Contract
- Document No. 10: Model Documents to be used by Bidders
- Document No. 11: Justifications of Preliminary Studies
- Document No. 12: List of Banking Establishments and Financial Bodies Authorised to Issue Bonds for Public Contracts

Document No. 1
Tender Notice

REPUBLIQUE DU CAMEROUN
Paix-Travail-Patrie
.....
MINISTERE DE LA DÉCENTRALISATION
ET DU DEVELOPPEMENT LOCAL
.....
DELEGATION REGIONALE DU NORD OUEST
.....
DEPARTEMENT DE NGOKETUNJIA
.....
ARRONDISSEMENT DE NDOP
.....
COMMUNE DE NDOP
.....
SERVICE DE PASSATION DES
MARCHES PUBLICS



REPUBLIC OF CAMEROON
Peace-Work- Fatherland
.....
MINISTRY OF DECENTRALISATION
AND LOCAL DEVELOPMENT
.....
NORTH WEST REGIONAL DELEGATION
.....
NGOKETUNJIA DIVISION
.....
NDOP SUB- DIVISION
.....
NDOP COUNCIL
.....
SERVICE FOR THE AWARD OF PUBLIC
CONTRACTS

TENDER NOTICE

OPEN NATIONAL INVITATION TO TENDER BY EMERGENCY PROCEDURE
N°/ONIT/MINDDEVEL/NC/NCITB/BIPMINTP/ 2026 OF THE
CONSTRUCTION WORKS FOR A PERMANENT 6 M REINFORCED CONCRETE BRIDGE IN THE HAUSA QUARTER, INCLUDING THE CONSTRUCTION OF A 2 M × 2 M BOX CULVERT ALONG THE BAMUNKA-NDOP ROAD SECTION; CONSTRUCTION WORKS FOR A PERMANENT 7 M LINEAR REINFORCED CONCRETE BRIDGE OVER THE UPPER KAKE RIVER IN BAMUNKA VILLAGE, ALONG THE BAMUNKA-NDOP ROAD; AND CONSTRUCTION WORKS FOR A PERMANENT 8 M LINEAR REINFORCED CONCRETE BRIDGE OVER THE UPPER MUNJONG RIVER ALONG THE BAMUNKA-NDOP ROAD SECTION IN NDOP MUNICIPALITY, NGOKETUNJIA DIVISION IN NORTH WEST REGION

1. Subject of the invitation to tender:

Within the framework of 2026 BIP MINTP, the Mayor NDOP Council; Project Owner and Contracting Authority hereby launches an Open National Invitation to Tender by Emergency Procedure CONSTRUCTION WORKS FOR A PERMANENT 6 M REINFORCED CONCRETE BRIDGE IN THE HAUSA QUARTER, INCLUDING THE CONSTRUCTION OF A 2 M × 2 M BOX CULVERT ALONG THE BAMUNKA-NDOP ROAD SECTION; CONSTRUCTION WORKS FOR A PERMANENT 7 M LINEAR REINFORCED CONCRETE BRIDGE OVER THE UPPER KAKE RIVER IN BAMUNKA VILLAGE, ALONG THE BAMUNKA-NDOP ROAD; AND CONSTRUCTION WORKS FOR A PERMANENT 8 M LINEAR REINFORCED CONCRETE BRIDGE OVER THE UPPER MUNJONG RIVER ALONG THE BAMUNKA-NDOP ROAD SECTION IN NDOP MUNICIPALITY, NGOKETUNJIA DIVISION IN NORTH WEST REGION

2. Nature of work:

Work to be done consists of

- Site Installation
- Site Preparation
- General Earth Works
- Foundations - Abutment - Wing Walls - Deck
- Equipment
- Painting

3. Execution deadline

The maximum deadline provided by the Contracting Authority for the execution of the works forming the subject of this invitation to tender is **180 days for each phase**

4. Lots

The works is in single lot.

5. Estimated cost

The estimated cost after preliminary studies is **two hundred million twenty -three thousand one and forty -six (200,023,146) Francs CFA**. This amount is distributed into three phases as follows:

PHASE	DESCRIPTION	FINANCIAL YEAR	AMOUNT (FCFA)
1	THE CONSTRUCTION WORKS FOR A PERMANENT 6 M REINFORCED CONCRETE BRIDGE IN THE HAUSA QUARTER, INCLUDING THE CONSTRUCTION OF A 2 M × 2 M BOX CULVERT ALONG THE BAMUNKA-NDOP ROAD SECTION	2026	78,643,698
2	CONSTRUCTION WORKS FOR A PERMANENT 7 LINEAR METER REINFORCED CONCRETE BRIDGE OVER THE UPPER KAKE RIVER IN BAMUNKA VILLAGE, ALONG THE BAMUNKA-NDOP ROAD		56,215,285
3	CONSTRUCTION WORKS FOR A PERMANENT 8 M LINEAR REINFORCED CONCRETE BRIDGE OVER THE UPPER MUNJONG RIVER ALONG THE BAMUNKA-NDOP ROAD SECTION		65,165,163
GRAND TOTAL			200,023,146

6. Participation and origin

Participation to this invitation to tender is open to Cameroonian enterprises that are in compliance with the fiscal laws.

7. Financing

Works which form the subject of this invitation to tender shall be financed by the 2026 BIP MINTP Budget.

8. Bid bond

Each bidder must include in his administrative documents, a bid bond issued in line with the prescriptions of the "Caisse des Depots Et Consignations-CDEC" by a first-rate banking establishment or an insurance company approved by the Ministry in charge of finance and whose list is found in document No. 13 of the Tender File, of an amount of **FOUR MILLION (4,000,000) FCFA**, valid for thirty (30) days beyond the date of validity of bids.

9. Consultation of Tender File:

The file may be consulted during working hours at the technical service of NDOP Council.

Telephone N° 677 62 25 01 as soon as this notice is published.

10. Acquisition of tender file:

The file may be obtained from the Award service of the NDOP Council, Telephone N° 677 62 25 01 as soon as this notice is published against payment of a non-refundable sum of **one hundred and twenty-five thousand (125,000) F CFA**, payable at the NDOP Council Municipal Treasury, representing the cost of purchasing the tender file.

11. Submission of bids:

Each offer drafted in English or French in 07 (seven) copies including 01 (one) original and 06 (six) copies should reach the NDOP Council premises not later than ~~05 MAY 2026~~ at 10.00 AM local time and should carry the inscription:

OPEN NATIONAL INVITATION TO TENDER BY EMERGENCY PROCEDURE
N°...../ONIT/MINDDEVEL/NC/NCITB/ BIPMINTP / 2026/ OF ~~08 APR 2026~~ FOR THE
CONSTRUCTION WORKS FOR A PERMANENT 6 M REINFORCED CONCRETE BRIDGE IN THE HAUSA
QUARTER, INCLUDING THE CONSTRUCTION OF A 2 M × 2 M BOX CULVERT ALONG THE BAMUNKA-
NDOP ROAD SECTION; CONSTRUCTION WORKS FOR A PERMANENT 7 M LINEAR REINFORCED
CONCRETE BRIDGE OVER THE UPPER KAKE RIVER IN BAMUNKA VILLAGE, ALONG THE BAMUNKA-
NDOP ROAD; AND CONSTRUCTION WORKS FOR A PERMANENT 8 M LINEAR REINFORCED
CONCRETE BRIDGE OVER THE UPPER MUNJONG RIVER ALONG THE BAMUNKA-NDOP ROAD
SECTION IN NDOP MUNICIPALITY, NGOKETUNJIA DIVISION IN NORTH WEST REGION
"TO BE OPENED ONLY DURING THE BID-OPENING SESSION"

12. Admissibility of bids

Under penalty of being rejected, only originals or true copies certified by the issuing service or administrative authorities (Senior Divisional Officer, Divisional Officers) must imperatively be produced in accordance with the Special Regulations of the invitation to tender.

They must obligatorily be **not older than three (3) months** preceding the date of launching of the tenders or may be established after the signature of the tender notice

Any bid not in compliance with the prescriptions of the Tender File shall be declared inadmissible. This refers especially to the absence of a bid bond issued by a first-rate bank approved by the Minister in charge of Finance.

13. Opening of bids:

The bids shall be opened in a single phase. The opening of the administrative documents, the Technical and Financial offers will take place on the ~~05 MAY 2026~~ at 11 AM local time, at the Conference hall of NDOP Council by the NDOP Council Internal Tenders' Board. Only bidders may attend or be represented by duly mandated persons of their choice.

14. Evaluation criteria

The bids shall be evaluated according to the main criteria as follows:

A. Eliminatory criteria

1. Absence or insufficient bid bond (outright elimination);
2. Absence or non-conformity of a document in the administrative file
3. False declaration or falsified documents;
4. Incomplete financial file;
5. Omission of a unit price in the financial bid;
6. Deadline for delivery higher than prescribed;
7. Non respect of 75% of essential criteria;
8. External envelope carrying a sign that can identify the bidder;

During the opening session of the bids if a document of the administrative bid is absent or noncompliant, the bidder will be given forty-eight (48) hours to produce or replace the said document else it will be eliminated during the evaluation of the bids. No such document will be accepted after this deadline.

B. Essential criteria

- 1- General presentation of the tender files;
- 2- Financial capacity;
- 3- References of the company in similar achievements;

- 4- Quality of the personnel;
- 5- Technical organization of the works;
- 6- Safety measures on the site;
- 7- Logistics;
- 8- Attestation and report of site visit;
- 9- Special Technical Clauses initialed in all the pages;
- 10- Special Administrative Clauses completed and initialed in all the pages.

These essential criteria are subject to lower limits, the details of which are spelled out in the Special Regulations of the invitation to tender

15. Award

This evaluation will be done in a purely binary method with a positive **(Yes)** or negative **(No)** with an acceptable minimum of **75%** of the essential criteria taken into account.

The contract will be awarded to the bidder who would have proposed the offer with the lowest amount, in conformity with the regulations of the Tender Documents and having satisfied to **100%** of the eliminatory criteria and at least **75%** of the essential criteria.

Pursuant to justification by bidder, unconvincing abnormally low costing will not be accepted spelled out in the Special Regulations of the invitation to tender of this consultation.

16. Validity of bids

Bidders will remain committed to their offers for ninety (90) days from the deadline set for the submission of tenders.

17. Complementary information

Complementary technical information may be obtained during working hours at the Technical Service of the NDOP Council Telephone N° **677 62 25 01**

Done at NDOP on the, 08 AVR 2026

Copies:

- MINMAP
- ARMP
- Chairperson of TB
- Notice Board
- File/archive

The Project Owner
(Contracting Authority)
THE MAYOR - NDOP COUNCIL



Daniel Belengka
MD(PhD) / SURGERY / ORTHOPAEDIC
THE MAYOR / LE MAIRE

REPUBLIQUE DU CAMEROUN
Paix-Travail-Patrie
.....
MINISTRE DE LA DÉCENTRALISATION
ET DU DEVELOPPEMENT LOCAL
.....
DELEGATION REGIONALE DU NORD OUEST
.....
DEPARTEMENT DE NGOKETUNJIA
.....
ARRONDISSEMENT DE NDOP
.....
COMMUNE DE NDOP
.....
SERVICE DE PASSATION DES
MARCHES PUBLICS



REPUBLIC OF CAMEROON
Peace-Work- Fatherland
.....
MINISTRY OF DECENTRALISATION
AND LOCAL DEVELOPMENT
.....
NORTH WEST REGIONAL DELEGATION
.....
NGOKETUNJIA DIVISION
.....
NDOP SUB- DIVISION
.....
NDOP COUNCIL
.....
SERVICE FOR THE AWARD OF PUBLIC
CONTRACTS

AVIS D'APPEL D'OFFRES

AVIS D'APPEL D'OFFRES NATIONAL OUVERT EN PROCEDURE D'URGENCE
N° ¹⁰.../AONO/MINDDEVEL/CN/CIPM-CN/BIP MINTP/ 2026 DU ^{08 AVR 2026}..... POUR LES TRAVAUX
DE CONSTRUCTION DE TROIS PONTS : LE PONT EN BÉTON DÉFINITIF DE 6M METRE QUARTIER
HAUSA ET LE GNPS AVEC CONSTRUCTION D'UN DALOT DE 2X2 M SUR LE TRANÇON DE ROUTE
BAMUNKA -NDOP; TRAVAUX DE CONSTRUCTION DU PONT EN BÉTON DÉFINITIF DE 7ML
METRE SUR LE RIVIÈRE UPPER KAKE DANS LE VILLAGE BAMUNKA -NDOP , TRAVAUX DE
CONSTRUCTION DU PONT EN BÉTON DÉFINITIF DE 7ML METRE SUR LE RIVIÈRE UPPER KAKE
DANS LE VILLAGE BAMUNKA -NDOP, DANS LA MUNICIPALITE DE NDOP, DEPARTEMENT DE
NGOKETUNJIA, REGION DU NORD OUEST

1. Objet de l'Appel d'Offres

Dans le cadre de l'exercice budgétaire 2026 BIP MINTP, le Maire de la Commune de NDOP, Autorité Contractante lance, un Appel d'Offres National Ouvert en procédure d'urgence pour les travaux de construction de trois ponts : pont en béton définitif de 6m metre quartier Hausa et le GNPS avec construction d'un dalot de 2x2 m sur le trançon de route bamunka -pont en béton définitif de 7ml metre sur le rivière upper kake dans le village bamunka -ndop et pont en béton définitif de 8ml metre sur le rivière upper munjong sur le trançon de route bamunka dans la municipalité de Ndop, département de Ngoketunjia, Région du Nord-Ouest.

2. Consistance des travaux

Les travaux comprennent notamment :

- Installation du chantier
- Preparation du site
- Terrassements généraux
- Fondations-culées-ailes-tablier
- Equipement

3. Délais d'exécution

Le délai maximum prévu par le Maître d'Ouvrage Délégué pour la réalisation des travaux objet du présent appel d'offres est de **180 jours par phase**.

4. Allotissement

Les travaux sont en un lot unique.

5. Coût prévisionnel

Le coût prévisionnel des travaux à l'issue des études préalables est de **deux cent million vingt -trois mille cent quarante-six (200,023,146) francs CFA**. Ce montant est reparti en trois phases comme suit :

PHASE	DESCRIPTION	ANEE FINANCIERE	MONTANT (FCFA)
1	construction du pont en béton définitif de 6m metre quartier Hausa et le GNPS avec construction d'un dalot de 2x2 m sur le trançon de route bamunka -ndop dans la commune de ndop	2026	78,643, 698
2	construction du pont en béton définitif de 7ml metre sur le rivière upper kake dans le village bamunka -ndop dans la commune de ndop		56,215,285
3	construction du pont en béton définitif de 8ml metre sur le rivière upper munjong sur le trançon de route bamunka -ndop dans la commune de ndop		65,165,163
TOTAL GENERAL			200,023,146

6. Participation et origine

La participation à cette consultation est ouverte aux entreprises de droit camerounais.

7. Financement

Les travaux objet du présent appel d'offres sont financés par le Budget 2026,2027 et 2028 de Fond Routière de MINTP.

8. Cautionnement provisoire

Chaque soumissionnaire doit joindre à ses pièces administratives, une caution de soumission établie conformément aux prescriptions de Caisse des Depots Et Consignations-CDEC par une banque de premier ordre ou une compagnie d'assurance agréée par le Ministère chargé des finances et dont la liste figure dans la Pièce13 du DAO, d'un montant de **quatre million (4,000,000) FCFA** et valable pendant trente(30) jours au-delà de la date originale de validité des offres.

9. Consultation du Dossier d'Appel d'Offres

Le Dossier d'Appel d'Offres peut être consulté et obtenu aux heures ouvrables à la Mairie de NDOP, Service de Passation des Marchés **Tel: 677 62 25 01**; dès publication du présent avis.

10. Acquisition du Dossier d'Appel d'Offres

Le dossier peut être obtenu aux heures ouvrables à la Mairie de NDOP, Service de Passation **Tel: 677 62 25 01**; dès publication du présent avis, contre présentation d'une quittance de versement de la somme non remboursable de **cent -vingt mille (125, 000) Francs CFA** à la Trésorerie de la Commune de NDOP.

11. Remise des offres

Chaque offre rédigée en français ou en anglais en sept (07) exemplaires dont un (01) original et six (06) copies marquées comme telles, devra parvenir contre récépissé à la Mairie de NDOP, Service de Passation **Tel: 677 62 25 01**; au plus tard le à **10 heures locale** et devra porter la mention suivante :

15 MAI 2026

AVIS D'APPEL D'OFFRES NATIONAL OUVERT EN PROCEDURE D'URGENCE
N°/AONO/MINDDEVEL/CN/CIPM-CN/BIPMINTP / 2026 DU POUR LES TRAVAUX DE
**CONSTRUCTION DE TROIS PONTS : LE PONT DE LOWER MUNJONG (6ML) ; LE PONT DE
MENYAM (8ML) AVEC VOIES D'ACCES DANS LE VILLAGE DE BAMUNKA ; ET LE PONT (8ML) SUR
L'AXE HOPITAL GENERAL DE NDOP-PALAIS BAMUNKA (TRANSFERE AU PONT DE NTOCHEW
(8ML) SUR LE TRONCON MBUKEU-MESSI) DANS LA MUNICIPALITE DE NDOP, DEPARTEMENT
DE NGOKETUNJIA, REGION DU NORD OUEST**

«A N'OUVRIR QU'EN SEANCE DE DEPOUILLEMENT»

12. Recevabilité des offres

Sous peine de rejet, les pièces du dossier administratif requises doivent être produites en originaux ou en copies certifiées conformes par le service émetteur ou une autorité administrative (Préfet, Sous-préfet,...), conformément aux stipulations du Règlement Particulier de l'Appel d'Offres.

Elles doivent dater de moins de trois (03) mois précédant la date originale de dépôt des offres ou avoir été établies postérieurement à la date de signature de l'Avis d'Appel d'Offres.

Toute offre incomplète conformément aux prescriptions du Dossier d'Appel d'Offres sera déclarée irrecevable. Notamment l'absence de la caution de soumission délivrée par une banque de premier ordre ou une compagnie d'assurance agréée par le Ministère chargé des Finances.

13. Ouverture des plis

L'ouverture des plis se fera en un temps. L'ouverture des pièces administratives et des offres techniques et financières aura lieu à **11h00**, heure locale, dans la Salle de Conférence de Mairie de NDOP, par la Commission Interne de Passation de Marchés de la Commune de NDOP siégeant en présence des soumissionnaires ou de leurs représentants dûment mandatés et ayant une parfaite connaissance du dossier.

14. Critères d'évaluation

Les offres seront évaluées selon les principaux critères suivants :

A. Critères éliminatoires

Il s'agit notamment:

- 1- Absence ou insuffisance de la caution provisoire de soumission (élimination automatique) ;
- 2- Absence ou non-conformité d'une pièce administrative 48h après ouverture des plis;
- 3- Fausses déclarations ou pièces falsifiées;
- 4- Offre financière incomplète ;
- 5- Omission d'un prix unitaire ;
- 6- Délai d'exécution Superior aux délais impartie.
- 7- Le non-respect de 75% des critères essentiels ;
- 8- Enveloppe présentant un signe distinctif;

B - Critères essentiels

Les critères relatifs à la qualification des candidats porteront à titre indicatif sur:

- 1- Présentation générale de l'offre ;
 - 2- Capacité financière ;
 - 3- Références de l'entreprise dans les réalisations similaires ;
 - 4- Qualité du personnel ;
 - 5- Organisation technique des travaux ;
 - 6- Mesures de sécurité sur le site
 - 7- Moyens logistiques ;
 - 8- Attestation et rapport de visite de site
- 9- Cahier des Clauses Techniques Particulières paraphé à chaque page et signe au dernier page avec la mention : Lu et approuvé;
- 10- Cahier des Clauses Administratives Particulières complété et paraphé à chaque page et signe au dernier page avec la mention : Lu et approuvé

Les critères essentiels sont soumis à des minima dont le détail est donné dans le Règlement Particulier de l'Appel d'Offres (RPAO).

15. Attribution

Cette évaluation se fera de manière purement positive (oui) ou négative (non) avec un minimum acceptable d'au moins 75% de l'ensemble des critères essentiels pris en compte.

Le marché sera attribué au soumissionnaire qui aura proposé l'offre la moins disant, conforme pour l'essentiel aux prescriptions du Dossier d'Appel d'Offres, ayant satisfait à **100%** des critères éliminatoires et au moins 75% des critères essentiels.

16. Durée de validité des offres

Les soumissionnaires restent engagés par leurs offres pendant 90 jours à partir de la date limite fixée pour la remise des offres.

17. Renseignements complémentaires

Les renseignements complémentaires d'ordre technique peuvent être obtenus auprès de Mairie de NDOP, Service de Passation, **Tel: 677 62 25 01;**

Fait à NDOP, le **08 AVR. 2026**

Copie :

- ARMP;
- MINMAP
- Présidents CPM;
- Affichage.



Le Maire de NDOP,

Dr. Ntoh Daniel Belengha
MD(PHD) / SURGERY / ORTHOPAEDIC
THE MAYOR / LE MAIRE

Document No. 2

**GENERAL REGULATIONS OF THE INVITATION TO
TENDER**

TABLE OF CONTENTS

A. General	
Article 1: Scope of the tender	
Article 2: Financing.....	
Article 3: Fraud and corruption.....	
Article 4: Candidates admitted to compete.....	
Article 5: Building materials, materials, supplies, equipment and authorised services.....	
Article 6: Qualification of the bidder.....	
Article 7: Visit of site of works.....	
B. Tender File.....	
Article 8: Content of Tender File.....	
Article 9: Clarifications on Tender File and complaints	
Article 10: Modification of the Tender File.....	
C. Preparation of Bids	
Article 11: Tender fees.....	
Article 12: Language of bid.....	
Article 13: Constituent documents of the bid.....	
Article 14: Amount of bid.....	
Article 15: Currency of bid and payment.....	
Article 16: Validity of bids.....	
Article 17: Bid bond.....	
Article 18: Varying proposals by bidders.....	
Article 19: Preparatory meeting to the establishment of bids.....	
Article 20: Form and signature of bids.....	
D. Submission of bids.....	
Article 21: Sealing and marking of bids.....	
Article 22: Date and time-limit for submission of bids.....	
Article 23: Out of time-limit bids.....	
Article 24: Modification, substitution and withdrawal of bids.....	
E. Opening and evaluation of bids	
Article 25: Opening of bids.....	
Article 26: Confidential nature of the procedure.....	
Article 27: Clarifications on the bid and contact with Contracting Authority.....	
Article 28: Determination of their compliance.....	
Article 29: Qualification of the bidder.....	
Article 30: Correction of errors.....	
Article 31: Conversion into a single currency.....	
Article 32: Evaluation of financial bids.....	
Article 33: National preference.....	
F. Award of the contract.....	
Article 34: Award.....	
Article 35: Right of the Contracting Authority to declare an invitation to tender unsuccessful or to cancel a procedure.....	
Article 36: Notification of the award of the contract.....	
Article 37: Signature of the contract.....	
Article 38: Final bond.....	

General Rules of the Invitation to Tender

A. General

Article 1: Scope of the tender

- 1.1 The Contracting Authority as defined in the Special Regulations of the invitation to tender hereby launches an invitation to tender for the construction of the works described in the Tender File and briefly described in the Special Regulations.
- 1.2 The bidder retained or the preferred bidder must complete the works within the time-limit indicated in the Special Regulations and which time-limit runs from the date of notification of the Administrative Order.
- 1.3 In this Tender File, the term "day" means a calendar day.

Article 2: Financing

The source of financing of the works forming the subject of this invitation to tender shall be specified in the Special Regulations.

Article 3: Fraud and Corruption

- 4.1 The Contracting Authority requires of bidders and contractors the strict respect of rules of professional ethics during the award and execution of public contracts. By virtue of this principle:
 - a) The following definitions shall be admitted:
 - i) Shall be guilty of "corruption" whoever offers, gives, requests or accepts any advantage in view of influencing the action of a public official during the award or execution of a contract;
 - ii) Is involved in "fraudulent manoeuvres" whoever deforms or distorts facts in order to influence the award or execution of a contract;
 - iii) "Collusive practices" shall mean any form of agreement between two or among several bidders (whether the Contracting Authority is aware or not) aimed at artificially maintaining the prices of bids at levels not corresponding to those resulting from competition;
 - iv) "Coercive practices" shall mean any form of harm against persons or their property or threats against them in order to influence their action during the award or execution of a contract.
 - b) Any proposed award shall be rejected if it is proved that the proposed preferred bidder is directly or through an intermediary, guilty of corruption or is involved in fraudulent manoeuvres, collusive or coercive practices for the award of this contract.
- 4.2 The Minister Delegate at the Presidency in charge of public contracts may, as a precaution, take a decision of exclusion from bidding for a period not exceeding two(2) years against any bidder found guilty of influence peddling, of conflicts of interest, insider trading, fraud, corruption or production of non-genuine documents in the bid, without prejudice to criminal proceedings that may be brought against him

Article 4: Candidates allowed to Compete

- 4.1 If the invitation to tender is restricted, consultation is addressed to all candidates retained after a pre-qualification procedure.
- 4.2 Generally, the invitation to tender is addressed to all entrepreneurs, subject to the following provisions:
 - (a) A bidder (including all members of a group of enterprises and all sub-contractors to the bidder), in accordance with the funding agreement.
 - (b) A bidder (including all members of a group of enterprises and all sub-contractors to the bidder) must not be in a situation of conflict of interest, subject to disqualification. A bidder shall be judged to be in a situation of conflict of interest if he:
 - i) Is or was associated in the past with an enterprise (or a subsidiary of this enterprise) which provided consultancy services for the conception, preparation of specifications and other documents used within the scope of contracts awarded for this invitation to tender; or
 - ii) Presents more than one bid within the context of invitation to tender, except authorised variants according to article 17, where need be; meanwhile, this does not prevent the participation of sub-contractors in more than one bid.
 - iii) The Contracting Authority or Project Owner has financial interests in the capital in a way as to compromise the transparency of the procedures of award of public contracts.

(c) The bidder must not have been excluded from bidding for public contracts.

(d) A Cameroonian public enterprise may participate in the consultation if it can demonstrate that it is

i) Legally and financially autonomous,

ii) Managed according to commercial laws and

iii) Not under the direct supervisory authority of the Contracting Authority or Project Owner.

Article 5: Building materials, materials, supplies, equipment and authorised services

5.1 Building materials, the contractor's materials, supplies, equipment and services forming the subject of this contract must originate from countries meeting the criteria of origin defined in the Special Regulations of the invitation to tender and all expenditure done within the context of the contract shall be limited to the said building materials, materials, supplies, equipment and services.

5.2 Within the meaning of this 5.1 above, the term "originate" shall designate the place where the goods are extracted, cultivated, produced, manufactured and from where the services originate.

Article 6: Qualification of bidder

6.1 As an integral part of their bid, bidders must:

(a) Submit a power of attorney making the signatory of the bid bound by the bid; and

(b) Provide all information (complete or update information included in their request for pre-qualification which may have changed in the case where the candidates took part in pre-qualification) requested of bidders in the Special Regulations of the invitation to tender, in order to establish their qualification to execute the contract.

Where necessary, bidders should provide information relating to the following points:

i) The production of certified balance sheets and recent turnovers;

ii) Access to a line of credit or availability of other financial resources;

iii) Pending litigations;

iv) Availability of indispensable equipment.

6.2 Bids presented by two or more associated undertakings (joint-contracting) must satisfy the following conditions:

(a) The bid must include all the information listed in article 6(1) above. The Special Regulations must indicate the information to be furnished by the group and that to be furnished by each member of the group;

(b) The bid and the contract must be signed in a way that is binding on all members of the group;

(c) The nature of the group (joint or several) must be specified in the Special Regulations and justified with the production of a joint venture agreement in due form;

(d) The member of the group designated as the representative will represent all the undertakings vis à vis the Project Owner and Contracting Authority with regard to the execution of the Contract;

(e) In case of joint co-contracting, the co-contractors shall share the sums which are paid by the Project Owner into a single account. On the other hand, each undertaking is paid into its own account by the Project Owner where it is joint co-contracting.

6.3 Bidders must equally present sufficiently detailed proposals to demonstrate that they comply with the technical specifications and execution time-limits set in the Special Regulations of the invitation to tender.

6.4 Bidders requesting to benefit from the margin of preference must furnish all the necessary information to prove that they satisfy the eligibility criteria set in article 33 of the General Regulations of the invitation to tender.

Article 7: Visit of works site

7.1 The bidder is advised to visit and inspect the site and its environs and obtain by himself and under his own responsibility, all the information which may be necessary for the preparation of the bid and the execution of the works. The related cost of the visit of the site shall be borne by the bidder.

7.2 The Project Owner shall authorise the bidder and his employees or agents to enter the premises and the land for the said visit but only on the express condition that the bidder, his employees and agents free the Project Owner, his employees and agents of any responsibility that may ensue and indemnify them if

necessary and that they shall remain responsible for any deadly or corporal accident, loss or material damages, costs and fees incurred from this visit.

7.3 The Project Owner may organise a visit of the site of the works during the preparatory meeting to establishing the bids mentioned in article 19 of the General Regulations of the invitation to tender.

B. Tender File

Article 8: Content of Tender File

8.1 The Tender File describes the works forming the subject of the contract, sets the consultation procedure of contractors and specifies the terms of the contract. Besides the addendum (addenda) published in accordance with article 10 of the General Regulations of the invitation to tender, it includes the following documents:

- Document No. 1. The tender notice;
- Document No. 2. The General Regulations of the invitation to tender;
- Document No. 3. The Special Regulations of the invitation to tender;
- Document No. 4. The Special Administrative Conditions;
- Document No. 5. The Special Technical Conditions;
- Document No. 6. The schedule of unit prices;
- Document No. 7. The bill of quantities and estimates;
- Document No. 8. The sub details of unit prices;
- Document No. 9. Model documents of the contract:
 - a. The execution schedule;
 - b. Model of forms presenting the equipment, personnel and references;
 - c. Model bidding letter;
 - d. Model bid bond;
 - e. Model final bond;
 - f. Model of bond of start-off advance;
 - g. Model of guarantee in replacement of the retention fund;
 - h. Model contract;
- Document No. 10. Models to be used by bidders;
 - a. Model contract;
- Document No. 11. Justifications of preliminary studies; to be filled by the Project Owner;
- Document No. 12. List of first grade banking establishments or financial institutions approved by the Minister in charge of Finance authorised to issue bonds for public contracts to be inserted by the Contracting Authority.

8.2 The bidder must examine all the regulations, forms, conditions and specifications contained in the Tender File. It is up to him to furnish all the information requested and prepare a bid in compliance with all aspects of the said file.

Article 9: Clarifications on the Tender File and complaints

- 9.1 Any bidder who wants to obtain clarifications on the Tender File may request them from the Contracting Authority in writing or by electronic mail (fax or e-mail) at the Contracting Authority's address indicated in the Special Regulations of the invitation to tender and send a copy to the Project Owner. The Contracting Authority replies in writing to any request for clarification received at least fourteen (14) days prior to the deadline for the submission of bids.
A copy of the Contracting Authority's response, indicating the question posed but not mentioning the author, is addressed to all bidders who bought the Tender File.
- 9.2 Between the publication of the tender notice including the pre-qualification phase of candidates and the opening of bids, any bidder who feels aggrieved in the public contracts award procedure may lodge a complaint to the Minister in charge of Public Contracts.
- 9.3 A copy of the complaint should be addressed to the Contracting Authority and to the body in charge of the regulation of public contracts and the chairperson of the Tenders Board.

9.4 The Contracting Authority has five (5) days to react. A copy of the reaction shall be forwarded to MINMAP and the body in charge of the regulation of Public Contracts.

Article 10: Amendment of the Tender File

10.1 The Contracting Authority may at any moment, prior to the deadline for the submission of bids and for any reason, be it at his initiative or in reply to a request for clarification formulated by a bidder, amend the Tender File by publishing an addendum.

10.2 Any published addendum shall be an integral part of the Tender File, in accordance with article 8.1 of the General Regulations of the invitation to tender and must be communicated in writing or made known by a traceable means to all bidders who bought the Tender File.

10.3 In order to give bidders sufficient time to take account of the addendum in the preparation of their bids, the Contracting Authority may postpone as is necessary, the deadline for the submission of bids, in accordance with provisions of article 22 of the General Regulations of the invitation to tender.

C. Preparation of bids

Article 11: Tender Costs

The candidate shall bear the costs related to the preparation and presentation of his bid and the Contracting Authority and the Project Owner shall in no case be responsible for these costs nor pay for them whatever the evolution or outcome of the invitation to tender procedure.

Article 12: Language of Bid

The bid as well as any correspondence and any document exchanged between the bidder and the Contracting Authority shall be written in English or French. Complementary documents and the forms provided by the bidder may be written in another language on condition that a precise translation into either English or French of the passages concerning the bid is included; in which case for reasons of interpretation, the translation shall be considered to be authentic.

Article 13: Constituent Documents of the Bid

13.1 The bid presented by the bidder shall include the documents detailed in the Special Regulations of the invitation to tender, duly filled and put together in three volumes:

a. *Volume 1: Administrative file*

It includes:

i) All documents attesting that the bidder:

- has subscribed to all declarations provided for by the laws and regulations in force;
- paid all taxes, duties, contributions, fees or deductions of whatever nature;
- is not winding up or bankrupt;
- is not the subject of an exclusion order or forfeiture provided for by the law in force;

ii) The bid bond established in accordance with the provisions of article 17 of the General Regulations of the invitation to tender;

iii) The written confirmation empowering the signatory of the bid to commit the bidder, in accordance with the provisions of article 6(1) the General Regulations of invitation to tender.

b. *Volume 2: Technical bid*

b.1 Information on qualifications

The Special Regulations list the documents to be furnished by bidders to justify the qualification criteria mentioned in article 6(1) of the Special Regulations of the invitation to tender.

b.2 Methodology

The Special Conditions of the invitation to tender specifies the constituent elements of the technical bid of the bidders especially: a methodological statement on an analysis of the works and specifying the organisation and programme which the bidder intends to put in place or use to execute the works (installations, schedule, Quality Assurance Plan (QAP), sub-contracting, attestation of visit of the site, where necessary, etc.).

b.3 Proof of Acceptance of Conditions of the Contract

The bidder shall submit duly initialled copies of the administrative and technical documents relating to the contract, namely:

1. The Special Administrative Conditions (SAC);

2. The Special Technical Conditions (STC).

b.4 Commentaries (optional)

A commentary on the technical choices of the project and possible proposals

c. Volume 3: Financial bid

The Special Regulations specify the elements that will help in justifying the cost of the works, namely:

1. The signed and dated original bid prepared according to the attached model, stamped at the prevailing rate;
2. The duly filled Unit Price Schedule;
3. The duly filled detailed estimates;
4. The sub-details of prices and/or breakdown of all-in prices;
5. The projected schedule of payments, where need be.

In this regard, the bidders will use the documents and models provided in the Tender File, subject to the provisions of article 17(2) of the General Regulations of the invitation to tender concerning the other possible forms of guarantees.

13.2 If in accordance with the provisions of the Special Regulations of the invitation to tender, the bidders present bids for several lots of the same invitation to tender, they could indicate rebates offered in case of award of more than one lot.

Article 14: Bid Price

14.1 Except otherwise stated in the Tender File, the amount of the contract shall cover all the works described in article 1.1 of the General Regulations of the invitation to tender, on the basis of the price schedule and the detailed bill of quantities and estimates presented by the bidder.

14.2 The bidder shall fill the unit prices and totals of all items on the schedule and bill of quantities and estimates.

14.3 Subject to contrary provisions provided for in the Special Regulations and in the Special Administrative Conditions, all dues, taxes and fees payable by the bidder on grounds of the contract or on any other ground, thirty (30) days prior to the submission of the bids, shall be included in the prices and in the total amount of the bid presented by the bidder.

14.4 If a price revision/updating clause is provided for in the contract, the date of establishment of the initial price, as well as the price revision/updating conditions for the said price must be specified. This is with the understanding that any contract of duration less than one (1) year shall not be subject to price revision.

14.5 All unit prices must be justified by sub-details established in accordance with the structure proposed in document 8 of the Tender File.

Article 15: Currency of Bid and Payment

15.1 In case of international invitations to tender, the currencies of the bid shall follow the provisions of either Option A or Option B below, the applicable option being that retained in the Special Regulations of the invitation to tender.

15.2 Option A: The amount of the bid shall be entirely made in the national currency.

The amount of the bid, unit prices of the price schedule and the prices of the bill of quantities and estimates are completely made in CFA francs in the following manner:

- a) Prices shall be entirely drawn in the national currency. The bidder who intends to commit expenditures in other currencies for the execution of the works shall indicate in the annex to the bid the percentage(s) of the amount of the bid necessary to cover the needs in foreign currencies, without exceeding the maximum of the three currencies of member countries of the funding institution of the contract.
- b) The exchange rates used by the bidder to convert his bid into the national currency shall be specified by the bidder in an annex to the bid in compliance with the specifications of the Special Regulations. These rates shall be applied for any payment within the framework of the contract so that the retained bidder does not bear any change in the exchange rate.

15.3 Option B: The amount of the bid shall be directly made in the national and foreign currency at the rates fixed in the Special Regulations.

The bidder shall draw the unit prices of the price schedule and the prices of the bill of quantities and estimates in the following manner:

- (a) The prices of inputs necessary for the works which the bidder intends to procure in the Contracting Authority's country shall be in currency of the Contracting Authority's country specified in the Special Regulations and called "national currency";
- (a) The prices of inputs necessary for works which bidder intends to procure out of the Contracting Authority's country shall be in the currency of the country of origin of the bidder or of the currency of an eligible member country widely used in international trade.

15.4 The Contracting Authority may request the bidders to explain the needs in national and foreign currencies and to justify that the amounts included in the unit and total prices and indicated in annex to the bids are reasonable; to this end, a detailed statement of their needs in foreign currencies shall be furnished by the bidder.

15.5 During the execution of the works, most of the foreign currency to be paid as part of contract may be revised by mutual agreement between the Contracting Authority and the entrepreneur in a way as take account of any modification in the foreign currency needs within the context of the contract.

Article 16: Validity of bids

16.1 Bids must remain valid during the period stated in the Special Regulations from the date of submission of the bids fixed by the Contracting Authority, in application of article 22 of the Special Regulations. A bid valid for a shorter period shall be rejected by the Contracting Authority as not being in compliance.

16.2 Under exceptional circumstances, the Contracting Authority may seek the approval of bidders to extend the validity time-limit. The request and the responses that will be given shall be in writing (or by fax). The validity of the bid bond provided for in article 17 of the General Regulations shall equally be extended for a corresponding duration. A bidder may refuse to extend the validity of his bid without losing his bid bond. A bidder who consents to an extension shall not be asked to modify his bid nor shall he be authorised to do so.

16.3 Where the contract does not include a price revision clause and that the period of validity of bids is extended by more than sixty (60) days, the amounts payable to the bidder retained shall be updated by application of the related formula featuring in the request for extension that the Contracting Authority addressed to bidders.

The updating period shall run from the date of overrun of sixty (60) days to the date of notification of the contract or the Administrative Order for start of execution of works by the retained bidder, as specified in the Special Administrative Conditions. The effect of updating shall not be taken into account for purposes of evaluation of bids.

Article 17: Bid bond

17.1 In application of article 13 of the General Regulations, the bidder shall furnish a bid bond of the amount specified in the Special Regulations and which bid bond shall be a full part of his bid.

17.2 The bid bond must conform to the model presented in the Tender File; other models may be authorised subject to the prior approval of the Contracting Authority. The bid bond will remain valid for thirty (30) days beyond the original date set for the validity of bids or any other validity time-limit requested by the Contracting Authority and accepted by the bidder, in accordance with the provisions of article 16 (2) of the General Regulations.

17.3 Any bid without an acceptable bid bond shall be rejected by the Tenders Board as not in conformity. The bid bond of associated enterprises must be established in the name of the group submitting the bid and mention each member of the associated grouping.

17.4 The bid bonds of bidders who are not retained shall be returned within fifteen (15) days after publication of the award result.

17.5 The bid bond of the successful bidder shall be released as soon as the latter would have signed the contract and furnished the required final bond.

17.6 The bid bond may be seized:

- a. If the bidder withdraws his bid during the period of validity;
- b. If the retained bidder:
 - i) Fails in his obligation to register the contract in application of article 38 of the General Regulations;
 - ii) fails in his obligation to furnish the required final bond in application of article 38 of the General Regulations;
 - iii) Refuses to receive notification of the Administrative Order to commence execution.

Article 18: Varying proposals of bidders

- 18.1 Where the works can be executed within variable deadlines, the Special Regulations shall specify these deadlines and shall indicate the method retained for the evaluation of the completion deadline proposed by the bidder within the specified deadlines. Bids that propose deadlines beyond those specified shall be considered as not being in conformity.
- 18.2 Except in the case mentioned in article 18(3) below, bidders wishing to offer technical variants must first assess the basic solution of the Contracting Authority as described in the Tender File and furnish in addition all the information which the Contracting Authority needs for a complete evaluation of the proposed variant, including the plans, calculations, technical specifications, sub-details of prices and proposed construction methods and all other useful information. If necessary, the Contracting Authority will examine only the technical variants of the bidder whose bid is in compliance with the basic solution has been evaluated as the lowest bid.
- 18.3 When according to the Special Regulations the bidders are authorised to directly submit the technical variants for certain parts of the works, these parts of the works must be described in the technical specifications. Such variants shall be evaluated on their own merit in accordance with the provisions of article 31(2) (g) of the General Regulations.

Article 19: Preparatory meeting to the establishment of bids

- 19.1 Except otherwise stipulated in the Special Regulations, a bidder may be invited to take part in a preparatory meeting which will hold at the date and place indicated in the Special Regulations.
- 19.2 The subject of the preparatory meeting shall be to furnish clarifications and answer any questions which may be raised at this stage.
- 19.3 As much as possible, the bidder is requested to submit any question in a way as to reach the Contracting Authority at least one week before the meeting. The Contracting Authority may not reply to questions received too late. In this case, the questions and answers shall be transmitted according to the methods set in article 19(4) below.
- 19.4 The minutes of the meeting, including the text of the questions asked and the replies given, including questions prepared after the meeting, shall be forwarded immediately to everyone who bought the Tender File. Any modification of documents of the Tender File listed in article 8 of the General Regulations which may prove to be necessary at the end of the preparatory meeting shall be done by the Contracting Authority by publishing an addendum in accordance with the provisions of article 10 of the General Regulations and not through the minutes of the preparatory meeting.
- 19.5 The fact that a bidder does not attend a preparatory meeting for the establishment of bids shall not be a reason for disqualification.

Article 20: Form and Signature of Bid

- 20.1 The bidder shall prepare an original of the constituent documents described in article 13 of the General Regulations in a volume clearly indicated "ORIGINAL". In addition, the bidder shall submit the number required in the General Regulations, bearing "COPY". In case of discrepancy, the original shall be considered as authentic.
- 20.2 The original and copies of the bid must be typed or written in indelible ink (photocopies shall be accepted in the case of copies) and shall be signed by the person(s) duly empowered to sign on behalf of the bidder, in accordance with article 6(1a) or 6(2c) of the General Regulations, as the case may be. All the pages of the bid containing alterations or changes must be initialled by the signatory (ies) of the bid.
- 20.3 The bid shall be bear - no modification, suppression or alteration unless such corrections are initialled by the signatory (ies) of the bid.

D. SUBMISSION OF BIDS

Article 21: Sealing and marking of bids

- 21.1 The bidder shall seal the original and each copy of the bid in separate envelopes (internal envelopes) by marking on these envelopes "**ORIGINAL**" and "**COPY**", as the case may be. The envelopes shall then be placed in another envelope which will equally be sealed but which will not give any indication regarding the identity of the bidder.
- 21.2 The external and internal envelopes:
- Should be addressed to the Contracting Authority at the address indicated in the Special Regulations;
 - Should bear the name and identification number of the project as indicated in the Special Regulations and bear the inscription "**TO BE OPENED ONLY DURING THE BID-OPENING SESSION**" as specified in the Special Regulations.
- 21.3 The internal envelopes should equally carry the name and address of the bidder in a way as to enable the Contracting Authority return the sealed bid if it is late in accordance with article 23 and 24 of the General Regulations.
- 21.4 If the external envelope is not sealed and marked as indicated in paragraphs 21(1) and 21(2) above, the Contracting Authority shall not be responsible if the bid is misplaced or opened prematurely.

Article 22: Date and time-limit for submission of bids

- 22.1. The bids must be received by the Contracting Authority at the address specified in article 21(2) of the Special Regulations not later than the date and time stated in the Special Regulations.
- 22.2. The Contracting Authority may, at his discretion, postpone the deadline set for the submission of the bids by publishing an addendum in accordance with the provisions of article 10 of the General Regulations. In this case, all the rights and obligations of the Contracting Authority and bidders previously governed by the initial date will henceforth be governed by the new date.

Article 23: Late Bids

Any bid received by the Contracting Authority beyond the deadline for the submission of bids in accordance with article 22 of the General Regulations shall be declared late and consequently rejected.

Article 24: Modification, substitution and withdrawal of bids

- 24.1. A bidder may modify or withdraw his bid after submitting it, on condition that the written notification of the modification or withdrawal is received by the Contracting Authority prior to the end of the time-limit prescribed for the submission of the bids. The said notification must be signed by an authorised representative in application of article 20(2) of the General Regulations. The modification or the corresponding replacement bid must be attached to the written notification. As the case may be, the envelopes must bear the inscription "**WITHDRAWAL**", and "**REPLACEMENT BID**" or "**MODIFICATION**".
- 24.2. Notification of modification, replacement or withdrawal of the bid by the bidder should be prepared, sealed, marked and forwarded in accordance with the provisions of article 21 of the General Regulations. Withdrawal may equally be notified by telex but should in this case be confirmed by a duly signed written notification whose date, post mark being authentic, shall not be posterior to the time-limit set for the submission of bids.
- 24.3. In application of article 24(1), bids being requested to be withdrawn by bidders shall be returned to them unopened.
- 24.4. No bid may be withdrawn during the interval between the submission of bids and the expiry of the validity of bids specified by the model tender. The withdrawal of a bid by a bidder during this interval may lead to the confiscation of the bid bond in accordance with the provisions of article 17(6) of the General Regulations.

E. OPENING OF ENVELOPES AND EVALUATION OF BIDS

Article 25: Opening of envelopes and petitions

- 25.1. The competent Tenders Board shall open the envelopes in single phase and in the presence of the representatives of bidders who wish to attend at the date, time and address specified in the Special Regulations. Representatives of bidders shall sign a register attesting to their presence.

- 25.2. Firstly, envelopes marked "**withdrawal**" shall be opened and the contents announced to the hearing of everyone, while the envelope containing the corresponding bid shall be returned to the bidder unopened. Withdrawal shall be allowed only if the corresponding notification contains a valid empowerment of the signatory to request this withdrawal and if this notification is read to the hearing of everyone. Then the envelopes marked "**Replacement bid**" are opened and announced to the hearing of everyone and the new corresponding bid substituted for the preceding one which will be sent to the bidder concerned unopened. The replacement of the bid shall only be allowed if the corresponding notification contains a valid empowerment of the signatory requesting the replacement and read to the hearing of everyone. Lastly, the envelopes marked "**modification**" shall be opened and their contents read to the hearing of everyone with the corresponding bid. The modification of the bid shall only be allowed if the corresponding notification contains a valid empowerment of the signatory requesting the modification and read to the hearing of everyone. Only bids which were opened and announced to the hearing of everyone during the opening of bids shall then be evaluated.
- 25.3. All envelopes shall be opened successively and the name of the bidder announced aloud as well as the possible modification mentioned, the price offered, including any rebates [*in case of opening of financial bids*] and any variant, where necessary, the existence of a guarantee of the bid if it is required and any other details which the Contracting Authority deems useful to be mentioned. Only rebates and variants of bids announced to the hearing of everyone during the opening of bids shall be submitted for evaluation.
- 25.4. Bids (and modifications received in accordance with the provisions of article 24 of the General Regulations) which were not opened and read to the hearing of everyone during the bid-opening session for whatever reason, shall not be submitted for evaluation.
- 25.5. Bid-opening minutes are recorded on the spot mentioning the admissibility of bids, their administrative regularity, prices, rebates and time-limits as well as the composition of the Evaluation sub-committee. A copy of the said minutes to which is attached the attendance sheet is handed over to all the participants at the end of the session.
- 25.6. At the end of each bid-opening session, the chairperson of the Tenders Board immediately hands over to the focal point designated by the body in charge of regulation of public contract an initialled copy of the bids presented by bidders.
- 25.7. In case of petition as provided for by the Public Contracts Code, it should be addressed to the Minister Delegate in charge of Public Contracts with copies to the body in charge of the regulation of public contracts, the head of structure to which is attached the Tenders Board concerned. It must reach within a maximum deadline of three (3) working days after the opening of bids in the form of a letter to which is obligatorily attached a sheet of the petition form duly signed by the petitioner and possibly by the chairperson of the Tenders Board.
- The Independent Observer attaches to his report the sheet that was handed to him, including any related commentaries or observations.

Article 26: Confidential Nature of the procedure

- 26.1. No information relating to the examination, clarification, evaluation and comparison of bids and verification of the qualification of the bidders and the recommendation for the award shall be given to bidders or to any person not concerned with the said procedure as long as the preferred bidder has not been made public, subject to the disqualification of the bid of the bidder and suspension of the authors from all activities in the domain of public contracts.
- 26.2. Any attempt by a bidder to influence the Tenders Board or the Evaluation sub-committee of bids or the Contracting Authority in its award decision may lead to the rejection of his bid.
- 26.3. Notwithstanding the provisions of paragraph 26.2 above, between the opening of bids and the award of the contract, if a bidder wishes to enter into contact with the Contracting Authority for reasons having to do with his bid may do so in writing.

Article 27: Clarifications on the bids and contact with the Contracting Authority

- 27.1. To ease the examination, evaluation and comparison of bids, the Tenders Board may, if it so desires, request any bidder to give clarifications on his bid. This request for clarification and the response thereto are formulated in writing but no change on the amount or content of the bid is sought, offered or

authorised, except it is necessary to confirm the correction of calculation errors discovered by the Evaluation Sub-committee during the evaluation in accordance with the provisions of article 30 of the General Regulations.

- 27.2. Subject to the provisions of paragraph 1 above, bidders shall not contact members of the Tenders Board and the Evaluation Sub-committee for questions related to their bids, between the opening of envelopes and the award of the contract.

Article 28: Determination of compliance of bids

- 28.1. The Evaluation sub-committee shall carry out a detailed examination of bids to determine if they are complete, if the required guarantees are furnished, if the documents were correctly signed and if generally the bids are in proper order.
- 28.2. The Evaluation sub-committee shall determine if the bid is essentially in compliance with the conditions fixed in the Tender File based on the content without recourse to external elements of proof.
- 28.3. A bid that complies with the Tender File shall essentially be a bid that respects all the terms, conditions and specifications of the Tender File, without substantial divergence or reservation. A substantial divergence or reservation is that:
- i) Which substantially limits the scope, quality or realisation of the works;
 - ii) Which substantially limits, contrary to the Tender File, the rights of the Contracting Authority or his obligations in relation to the contract;
 - iii) Whose correction would unjustly affect the competitiveness of the other bidders who presented bids that essentially complied with the Tender File
- 28.4. If a bid is essentially not in compliance, it shall be rejected by the competent Tenders Board and shall not subsequently be rendered in compliance.
- 28.5. The Contracting Authority reserves the right to accept or reject any modification, divergence or reservation. Modifications, divergences, variants and other factors which are beyond the requirements of the Tender File shall not be considered during the evaluation of bids.

Article 29: Qualification of the bidder

The Evaluation sub-committee shall ensure that the successful bidder retained for having submitted a bid substantially in compliance with the provisions of the Tender File, fulfils the qualification criteria stipulated in article 6 of the Special Regulations. It is essential to avoid any arbitrariness in determining qualification.

Article 30: Correction of Errors

- 30.1. The Evaluation sub-committee shall verify bids considered essentially in compliance with the Tender File to correct the possible calculation errors. The Evaluation sub-committee shall correct the errors in the following manner:
- (a) Where there is an incoherence between the unit price and the total obtained by multiplying the unit price by the quantity, the unit price being authentic, the total price shall be corrected, unless the Evaluation sub-committee judges that it is a gross error of decimal point in the unit price in which case the total price as presented shall be authentic and the unit price corrected.
 - (b) If the total obtained by addition or subtraction of the totals is not exact, the sub totals shall be considered authentic and the total corrected.
 - (c) Where there is a difference between the price indicated in words and in figures, the amount in words shall be considered authentic, unless the amount is linked to an arithmetical error confirmed by the sub-detail of the said price, in which case the amount in figures shall prevail subject to paragraphs (a) and (b) above.
- 30.2. The amount featuring in the bid shall be corrected by the Evaluation sub-committee, in accordance with the error correction procedure above and with confirmation by the bidder, the said amount shall be deemed to commit him.
- 30.3. If the bidder who presented the bid evaluated as the lowest refuses the correction thus carried out, his bid shall be rejected and the bid bond may be seized.

Article 31: Conversion into a single currency

- 31.1.** To facilitate the evaluation and comparison of bids, the Evaluation sub-committee shall convert the prices of bids expressed in various currencies into those in which the bid is payable in CFA francs.
- 31.2.** The conversion shall be done using the selling rate fixed by the Bank of Central African States (BEAC) under the conditions defined by the Special Regulations.

Article 32: Evaluation and comparison of financial bids

- 32.1.** Only bids considered as being in compliance, as per the provisions of article 28 of the General Regulations, shall be evaluated and compared by the Evaluation sub-committee.
- 32.2.** By evaluating the bids, the Evaluation Sub-committee shall determine for each bid the evaluated amount of the bid by rectifying the amount as follows:
- a) By correcting any possible error in accordance with the provisions of article 30.2 of the General Regulations;
 - b) By excluding projected sums and where necessary provisions for unforeseen occurrences featuring in the bill of quantities and estimates but by adding the amount of works done under State supervision where they are costed in a competitive manner as specified in the Special Regulations.
 - c) By converting into a single currency the amount resulting from the rectifications (a) and (b) above, in accordance with the provisions of article 31(2) of the General Regulations;
 - d) By appropriately adjusting any other modification, divergence or quantifiable reservation on technical or financial basis.
 - e) By taking into consideration the various execution time-limits proposed by the bidders, if they are authorised by the Special Regulations;
 - f) If need be, in accordance with the provisions of article 13(2) of the General Regulations and the Special Regulations by applying the rebates offered by the bidder for the award of more than one lot, if this invitation to tender is launched simultaneously for several lots.
 - g) If need be, in accordance with the provisions of article 18(3) of the Special Regulations and the Technical Specifications, the proposed technical variants, if they are permitted, shall be evaluated on their own merit and independently of the fact that the bidder offered or not a price for the technical solution specified by the Contracting Authority in the Special Regulations.
- 32.3.** The estimated effect of price revision formulae featuring in the GAC and SAC applied during the period of execution of the contract shall not be considered during the evaluation of bids.
- 32.4.** If the bid judged the lowest bid is considered abnormally low or strongly unbalanced in relation to the estimates of the Project Owner for the works to be executed in this contract, the Tenders Board may, from the sub-details of prices furnished by the bidder for any element or all the elements of the bill of quantities and estimates, verify if these prices are compatible with the construction methods and proposed calendar. In the case where the justifications presented by the bidder are not satisfactory, the Contracting Authority may reject the bid after the technical opinion of the Public Contracts Regulatory Agency.

Article 33: Preference granted national bidders

National contractors shall benefit from a margin of national preference during the evaluation of bids as provided for in the Public Contracts Code.

Article 34: Award

- 34.1.** The Contracting Authority shall award the contract to the bidder whose bid was judged essentially in compliance with the Tender File and who has the required technical and financial capacities to execute the contract satisfactorily and whose bid was evaluated as the lowest by including, where necessary, proposed rebates
- 34.2.** If, according to article 13(2) of the General Regulations, the invitation to tender comprises several lots, the lowest bid shall be determined by evaluating this contract with other lots to be awarded concurrently, by taking into account the rebates offered by the bidders in the case of more than one lot.
- 34.3.** Any award of contract shall be made to the bidder fulfilling the technical and financial capacities required resulting from the evaluation criteria and presenting the bid evaluated as the lowest.

Article 35: The right by the Contracting Authority to declare an invitation to tender unsuccessful or cancel a procedure

The Contracting Authority reserves the right to cancel a procedure of invitation to tender after the authorisation of the Minister Delegate at the Presidency in charge of Public Contracts where the bids have been opened or to declare an invitation to tender unsuccessful after the advice of the competent Tenders Board, without any claims being entertained.

Article 36: Notification of award of the contract

Before the expiry of the validity of the bids set in the Special Regulations, the Contracting Authority shall notify the preferred bidder by telecopy confirmed by registered mail or by any other means that his bid was retained. This letter will indicate the amount the Project Owner will pay the contractor to execute the works and the execution time-limit.

Article 37: Publication of results of award and petitions

- 37.1.** The Contracting Authority shall communicate to any bidder or administration concerned, upon request addressed to it within a maximum deadline of five (5) days after publication of the award results, the Independent Observer's report as well as the minutes of the award session of the related contract to which shall be attached the evaluation report of the bids.
- 37.2.** The Contracting Authority is bound to communicate the reasons for the rejection of bids of the bidders concerned who so request.
- 37.3.** After publication of the award results, bids that are not withdrawn within fifteen (15) days shall be destroyed, without any claims for compensation being entertained. Only the copy destined for the body in charge of regulation shall be kept.
- 37.4.** In case of petition, it should be addressed to the Public Contracts Authority, with copies to the body in charge of the regulation of public contracts, the Contracting Authority and the chairperson of the Tenders Board concerned.

It must take place within a maximum deadline of five (5) working days after the publication of the results.

Article 38: Signing of the contract

- 38.1.** After publication of the results, the draft contract subscribed by the successful bidder is submitted to the Tenders Board for examination and where applicable, to the Minister in charge of Public Contracts for prior endorsement.
- 38.2.** The Contracting Authority has a deadline of seven (7) days to sign the contract from the date of reception of the draft contract examined by the competent Tenders Board and subscribed by the successful bidder and where applicable, the endorsement of the Minister in charge of Public Contracts.
- 38.3.** The contract must be notified to the successful bidder within five (5) days of its date of signature.

Article 39: Final Bond

- 39.1.** Within twenty (20) days of the notification by the Contracting Authority, the contractor shall furnish the Project Owner with a final bond, to guarantee the complete execution of the works.
- 39.2.** The bond whose rate varies between 2 and 5 per cent of the amount of the contract inclusive of all taxes, may be replaced by a guarantee from a banking establishment approved according to the instruments in force with the Project Owner as beneficiary or by a joint or several guarantee.
- 39.3.** Small and medium-sized enterprises (SME) constituted of national capital and managed by nationals may, in lieu of the guarantee, provide a statutory lien or a bond issued by a banking establishment or first rate financial institution approved in accordance with the instruments in force.
- 39.4.** Failure to produce the final bond within the prescribed time limit shall likely cause the termination of the contract under the terms laid down in the General Administrative Conditions.

Document No. 3

SPECIAL REGULATIONS OF THE INVITATION TO TENDER

Special regulations of the invitation to tender

References of the General regulations	General
1.1	<p>Definition of works: FOR THE CONSTRUCTION WORKS FOR A PERMANENT 6 M REINFORCED CONCRETE BRIDGE IN THE HAUSA QUARTER, INCLUDING THE CONSTRUCTION OF A 2 M × 2 M BOX CULVERT ALONG THE BAMUNKA-NDOP ROAD SECTION; CONSTRUCTION WORKS FOR A PERMANENT 7 M LINEAR REINFORCED CONCRETE BRIDGE OVER THE UPPER KAKE RIVER IN BAMUNKA VILLAGE, ALONG THE BAMUNKA-NDOP ROAD; AND CONSTRUCTION WORKS FOR A PERMANENT 8 M LINEAR REINFORCED CONCRETE BRIDGE OVER THE UPPER MUNJONG RIVER ALONG THE BAMUNKA-NDOP ROAD SECTION IN NDOP MUNICIPALITY, NGOKETUNJIA DIVISION IN NORTH WEST REGION Name and address of the Contracting Authority: , The Mayor of NDOP, Reference of Invitation to tender: N°/ONIT/MINDDEVEL/NC/NCITB/BIPMINTP / 2026 OF</p>
1.2	Execution deadline: Six (06) months for each phase
2.1	<p>Source of financing Works which form the subject of this invitation to tender shall be financed by the 2026 BIP MINTP budget head 60 36 370232000003045 523411</p>
4.1	List of pre-qualified candidates, not applicable
5.1	Origin of building materials, equipment, materials, supplies and equipment: The materials will generally be from natural sources in Cameroon.

6.1 Evaluation criteria

The bids shall be evaluated according to the main criteria as follows:

A. Eliminatory criteria

- 1 Absence or insufficient bid bond (outright elimination);
2. Absence or non-conformity of a document in the administrative file
3. False declaration or falsified documents;
4. Incomplete financial file;
5. Omission of a unit price in the financial bid;
6. Deadline for delivery higher than prescribed;
7. Non respect of 75% of essential criteria;
8. External envelope carrying a sign that can identify the bidder;

During the opening session of the bids if a document of the administrative bid is absent or noncompliant, the bidder will be given forty-eight (48) hours to produce or replace said document else will be eliminated during the evaluation of the bids. No such document will be accepted after this deadline.

B. Essential criteria

- 1) General presentation of the bids;
- 2) Financial capacity;
- 3) References of the company in similar achievements;
- 4) Quality of the personnel;
- 5) Technical organization of the works;
- 6) Logistics;

- 7) Special Technical Clauses initialed in all the pages and signed on the last page;
- 8) Special Administrative Clauses completed and initialed in all the pages and signed on the last page.

The criteria relating to the qualification of candidates could be indicative on the following:
The essential criteria are subjected to minima whose detail is given in the Special Tender Regulation (RPAO). This evaluation will be done in a purely positive way (yes) or negative (no) with an acceptable minimum from at least 75% of the essential criteria taken in account.

The contract will be awarded to the bidder who would have proposed the offer with the lowest amount, in conformity with the regulations of the Tender Documents and having satisfied to **100%** of the eliminatory criteria and at least **75%** of the essential criteria.

ARTICLE 6: Language of the bids:

The offer like any correspondence and all documents concerning the tender, exchanged between the tenderer and the Project Owner will be written in French or English. The complementary documents and the printed papers form provided by the Bidder can be written in another language in condition of being accompanied by a precise translation in French or English; in which case and for purposes of interpretation of the offer, the translation will be taken.

PRESENTATION OF THE TENDER

The bids prepared in English or French and in seven (07) copies with one (01) original and six (06) copies marked thus, shall be presented in three (03) volumes as follows:

- A) **Administrative Documents**
 - B) **Technical Documents**
 - C) **Financial Documents**
- 5.1 **External envelope.**

Each bidder shall seal these three (03) envelopes (A, B and C) in one common envelope on which shall be written.

OPEN NATIONAL INVITATION TO TENDER

N°/ONIT/MINDDEVEL/NC/NCITB/ROAD FUND/ 2026 OF **FOR THE CONSTRUCTION WORKS FOR A PERMANENT 6 M REINFORCED CONCRETE BRIDGE IN THE HAUSA QUARTER, INCLUDING THE CONSTRUCTION OF A 2 M × 2 M BOX CULVERT ALONG THE BAMUNKA-NDOP ROAD SECTION; CONSTRUCTION WORKS FOR A PERMANENT 7 M LINEAR REINFORCED CONCRETE BRIDGE OVER THE UPPER KAKE RIVER IN BAMUNKA VILLAGE, ALONG THE BAMUNKA-NDOP ROAD; AND CONSTRUCTION WORKS FOR A PERMANENT 8 M LINEAR REINFORCED CONCRETE BRIDGE OVER THE UPPER MUNJONG RIVER ALONG THE BAMUNKA-NDOP ROAD SECTION IN NDOP MUNICIPALITY, NGOKETUNJIA DIVISION IN NORTH WEST REGION.**

“TO BE OPENED ONLY DURING THE BID-OPENING SESSION”

N.B: The external envelope should not carry any mark or sign that can lead to the identification of the bidder.

Internal envelopes

Three (03) internal envelopes must be sealed in an external envelope.

The first internal envelope shall be labeled; .

<<ENVELOPE A: ADMINISTRATIVE DOCUMENTS>> and shall contain the administrative documents of the enterprise. These documents shall be original or copies certified by competent authorities not more than three months.

DOCUMENTS.

DOCUMENT N°	DESCRIPTION	YES	NO
A.1	Declaration of intention to tender stamped with the tariff in force		
A.2	Certified Copy of the Business Registration, not more than three months old.		
A.3	Certificate of non-bankruptcy established by the Court of 1st instance or the Chamber Commerce, Industry and Trade of the place of residence of the bidder, not more than three (03) months.		
A.4	Attestation of bank account of the bidder, issued by a first rate-bank or an insurance company approved by the Ministry in charge of Finance or by a foreign bank the first order not more than three months.		
A.5	Purchase receipt of tender file issued by NDOP municipal treasury		
A.6	A bid bond of FOUR MILLION FOUR HUNDRED AND SIXTY-THREE (4,000,463) issued in line with the prescriptions of the "Caisse des Depots Et Consignations-CDEC" by a first rate-bank or an insurance company approved by the Ministry in charge of Finance in conformity with COBAC conditions.		
A.7	An attestation of non-exclusion from Public Contracts issued by the Public contract Regulatory Board (ARMP)		
A.8	An Attestation of the National Social Insurance Fund stating that the bidder has met all his obligations vis a vis the Fund; the attestation should be less than three months old.		
A.9	Certified Copy of a valid taxpayers card, delivered by the chief of center of Taxes.		
A.10	A Certificate of tax compliance attesting that the bidder has met all the statutory declarations in issues of taxes in the current financial year; this certificate should be less than three months old.		
A.11	Certified copy of certificate of categorization in the Road Sub-Sector (Category D enterprises only as per Circular Letter No 000005/LC/MINMAP/CAB OF 26 Dec 2023 on the implementation of the categorisation of Building and Public Works sector Enterprises within the framework of contracting public contracts)		
A.12	Plan of localization		

During the opening session of the bids if a document of the administrative bid is absent or noncompliant, the bidder will be given forty-eight (48) hours to produce or replace the said document else it will be eliminated during the evaluation of the bids. No such document will be accepted after this deadline.

The second Internal Envelope shall be labeled <<ENVELOPE B: TECHNICAL DOCUMENT>> and shall contain the following:

B.1	General presentation of the tender files	YES	NO
B.1.1	-Document spirally bound -Table of content page		
B.1.2	-Colour sheets separation - Presentation of documents in the order given in this tender		
B.2	LIST OF REFERENCES OF THE ENTERPRISE IN THE SIMILAR JOBS		
B.2.1	List of references of the enterprise in similar jobs justified by signed contracts of at least sixty million (60,000,000) FCFA (first, and last pages including the bill of quantities) and minutes of reception or attestation of clearances of works executed. Minimum acceptable: 02 Contracts realized in the domain of Road Sub-Sector over the past 05 years		
	1st Reference		
	2 nd reference		
B.3	QUALIFICATION AND EXPERIENCE OF SUPERVISORY STAFF		
B.3.1	01 works supervisor (at least civil or rural engineer or equivalent certificate)		
	Qualification of the works supervisor: (Civil or rural Engineering certificate (BAC +3) Professional experience of the project engineer ≥ 03 years (signed CV)		
	<ul style="list-style-type: none"> ➤ A certified copy of the technical diploma, ➤ Certified copy of ID card 		
	<ul style="list-style-type: none"> ➤ An Attestation of presentation of original of the technical diploma ➤ CV signed by the candidate, ➤ Commitment of availability 		
B.3.2	Site foreman (Civil Engineering Senior Technician)		
	Qualification of the Site foreman: (Senior Technician certificate in Civil Engineering (HND or equivalent certificate) Professional experience of the Site foreman ≥ 03 years (signed CV)		
	<ul style="list-style-type: none"> ➤ A certified copy of the technical diploma, ➤ Certified copy of ID card 		
	<ul style="list-style-type: none"> ➤ An Attestation of presentation of original of the technical diploma ➤ CV signed by the candidate, ➤ Commitment of availability 		
B.3.3	Chief Builder		
	Qualification of Chief Builder: (CAP certificate or equivalent) Professional experience >03years (certified copy of the technical diploma and signed CV only)		
B.3.4	Chief Carpenter		
	Qualification of Chief carpentry : (CAP certificate or equivalent) Professional experience >03years (certified copy of the technical diploma and signed CV only)		
B.4	TECHNICAL PROPOSALS		
B.4.1	Organigram of the project (Specify names of the personnel handling the various functions)		
B.4.2	Logical sequence for the execution of the task		
B.4.3	Organization of works/methodology		
B.4.4	Quality control method		
B.4.5	Environmental protection measures		
B.4.6	Security and safety at the site		

B.4.7	Planning of execution of works.		
B.5	LOGISTICS (Equipment put aside for this project)		
B.5.1	Proof of ownership or rental of a pick-up or other vans		
B.5.2	Proof of ownership or rental of a dump truck		
B.5.3	Proof of ownership or rental of a concrete vibrator		
B.5.4	Proof of ownership or rental of a concrete mixer		
B.5.5	Proof of ownership or rental of a Hand compactor		
B.5.6	Masonry Kit : Wheelbarrows, masonry clamps, masonry harmer 300g, shovel, dig axe, building level, masonry bucket , trowels, etc.		
B.5.7	Carpentry Kit : carpentry clamps, saws, harmers, etc.		
B.6	FINANCIAL CAPACITY		
B.6.1	An attestation of financial capacity (solvency) of the enterprise issued by a 1st class bank located in any area in Cameroon and approved by the Ministry of Finance and respect COBAC conditions. 75% of the project amount		
B.7	Attestation of site visit signed by the director of the Company on honour		
B.8	Comprehensive report of site visit signed by the company administrator and justified by photos		
B.9	Special Technical Clauses initialed in all the pages and last page signed and dated with the following note: Read and approved		
B.10	Special Administrative Clauses completed and initialed in all the pages and last page signed and dated with the following note: Read and approved		

ENVELOPE C- FINANCIAL FILE

No.	DESIGNATION.	YES	NO
C1	A submission letter, signed, dated and stamped.		
C2	Completed and signed frame work of unit prices.		
C3	Signed Bills of quantities and cost estimates indicating the total amount without taxes (HT) and with taxes (TTC)		
C4	Sub details of unit prices		

- The bidders will use for this purpose the documents and models envisaged in the Tender Documents, subject to the provisions of Article 19.2 of the RGAO concerning the other possible forms of bid bond.
- The various parts of the same file must be separated with colour guides from as well in the original as in the copies, so as to facilitate its examination

Supply price

ARTICLE 8: Currency of payment

This National Invitation to tender is awarded on total and contractual price, inclusive of all taxes, firm and non-revisable for the whole of the works and the equipment defined in the present Invitation to tender.

The corresponding amount will be calculated inclusive of all taxes and the prices will be obligatorily expressed in francs CFA.

The unit Schedule price expressed out in figures and letters and in seven (07) copies will be joined to the offer. In the event of error between the prices in figures and letters, the latter will precede and be used as a basis of calculation of the amount of the offer.

The establishment of the prices will be done on the basis of economic condition into force in Republic of Cameroon at the handover date of the offers.

ARTICLE 9: Transport and delivery

The materials for work must be protected during transportation through packaging whether by air, railway or road according as the case may be. The conditions of storage must be of tropical type.

ARTICLE 10: Guarantee and retention guarantee

10.1 Provisional guarantee

The amount of the provisional guarantee or guarantee of tender is fixed at **four million eight hundred thousand (4,800,000) FCFA**.

The time of validity of this guarantee is ninety (90) days as from the date of depositing of the offers.

10.2 Final Bond

The final Bond is fixed at two percent (2%) of the initial amount of the services envisaged in the country. It could be replaced by a guarantee personal and interdependent of a banking house approved by the Ministry of Finances following COBAC conditions.

It will have to be made up in the twenty (20) days following the notification of the signature of the contract in a bank approved by the Minister in charge of Finances.

10.3 Guarantee Retention

Guarantee Retention of ten percent (10%) will be operated on amount including all taxes of the contract.

The corresponding sum will be paid or the released guarantee, with the final reception of work.

ARTICLE 11: Period of validity of the offers

The bidder will remain committed to his offer for ninety (90) days as from the handover date of the offers.

If at the end of this period, the contract were not notified to him, the bidder will be able, either to cancel his offer, or to ask for a new negotiation of the unit prices.

ARTICLE 12: A number of copies of the offer which must be filled and sent

The tender, as all the parts accompanying it will have to be given in seven (07) copies, including one (01) original and six (06) copies. The bidder will present his dossier inside a sealed outer jacket being marked:

OPEN NATIONAL INVITATION TO TENDER BY EMERGENCY PROCEDURE

CONSTRUCTION WORKS FOR A PERMANENT 6 M REINFORCED CONCRETE BRIDGE IN THE HAUSA QUARTER, INCLUDING THE CONSTRUCTION OF A 2 M × 2 M BOX CULVERT ALONG THE BAMUNKA-NDOP ROAD SECTION; CONSTRUCTION WORKS FOR A PERMANENT 7 M LINEAR REINFORCED CONCRETE BRIDGE OVER THE UPPER KAKE RIVER IN BAMUNKA VILLAGE, ALONG THE BAMUNKA-NDOP ROAD; AND CONSTRUCTION WORKS FOR A PERMANENT 8 M LINEAR REINFORCED CONCRETE BRIDGE OVER THE UPPER MUNJONG RIVER ALONG THE BAMUNKA-NDOP ROAD SECTION IN NDOP MUNICIPALITY, NGOKETUNJIA DIVISION IN NORTH WEST REGION.

“TO BE OPENED ONLY DURING THE BID-OPENING SESSION”

ARTICLE 13: Date and latest time of deposit of offers

The offers will have to arrive under closed fold and seal latest at **10:00 AM**, by mail registered with acknowledgement of delivery or by deposit against receipt to the following address:

**MINISTRY OF DECENTRALIZATION AND LOCAL DEVELOPMENT
NDOP COUNCIL
SERVICE OF AWARD
Tel: 677 62 25 01;**

Beyond this time no offer will be received nor accepted.

ARTICLE 14: Opening of the tenders

The opening of the files will be carried out in the Conference room of the NDOP Council on **22/01/2026** as from **11:00 AM**, by the NDOP Council Internal Tender Board sitting in the presence of the bidders or their representatives and having a good knowledge of the file.

AWARD OF THE CONTRACT

ARTICLE 15: Award of the contract

The Tenders Board will propose to the Contracting Authority to award the contract to the bidder who will have presented the offer with the lowest offer, essentially conforming to the regulations the Tender File,

having satisfied to **100% of all the eliminatory criteria and at least 75%** of the essential criteria taken into account.

The decision carrying attribution of the contract will be published by way of press release or any other means of publication of use in the Administration.

If the contract passed on the basis of technical alternative suggested by the bidder, the contracting authority reserves the right to introduce all the provisions there allowing him to guarantee itself against the real overrun costs of the alternative compared to his estimate of origin. In the absence of these last precise details, any additional charge due to an alternative will be inadmissible.

To this end, it is specified that a bidder cannot claim to be compensated, if it is not taken action on his offer.

The contracting authority reserves the right not to take action on an Invitation to tender, if it did not obtain a proposal which appears acceptable to him.

DOCUMENT No. 4:

SPECIAL ADMINISTRATIVE CONDITIONS (SAC)

Table of contents

Chapter I: General

- Article 1 - Subject of the contract
- Article 2 - Award procedure
- Article 3 - Definitions and duties (article 2 of GAC supplemented)
- Article 4 - Language, applicable law and regulations
- Article 5 - Constituent documents of the contract (article 4 of GAC)
- Article 6 - General applicable instruments
- Article 7 - Communication (GAC articles 6 and 10 supplemented)
- Article 8 - Administrative Orders (article 8 of GAC supplemented)
- Article 9 - Contracts with conditional phases (article 15 of GAC)
- Article 10 - Contractor's personnel (article 15 of GAC supplemented)

Chapter II: Financial conditions

- Article 11 - Guarantees and bonds (articles 29 and 41 of GAC supplemented)
- Article 12 - Amount of contract (articles 18 and 19 supplemented)
- Article 13 - Place and method of payment
- Article 14 - Price variation (article 20 of GAC)
- Article 15 - Price revision formulas
- Article 16 - Price updating formulas (article 21 of GAC)
- Article 17 - Work under State supervision (article 22 of GAC supplemented)
- Article 18 - Evaluation of works (article 23 supplemented)
- Article 19 - Evaluation of supplies (article 24 of GAC) supplemented)
- Article 20 - Advances (article 28 of GAC)
- Article 21 - Payments for the works (articles 26, 27 and 30 of GAC supplemented)
- Article 22 - Interests on overdue payments (article 31 of GAC supplemented)
- Article 23 - Penalties for delay (article 32 of GAC supplemented)
- Article 24 - Payment in case of a group of enterprises (article 33 of GAC)
- Article 25 - Final detailed account (article 35 of GAC)
- Article 26 - General detailed account (article 35 of GAC)
- Article 27 - Tax and customs schedule (article 36 of GAC)
- Article 28 - Stamp duty and registration (article 37 of GAC)

Chapter III: Execution of the works

- Article 29 - Nature of works
- Article 30 - Obligations of the Project Owner (GAC supplemented)
- Article 31 - Execution deadline of contract (article 38 of GAC)
- Article 32 - Roles and responsibilities of the contractor (article 40 of GAC)
- Article 33 - Making available documents and site (article 42 of GAC)
- Article 34 - Insurance of structures and civil responsibility (article 45 of GAC)
- Article 35 - Documents to be furnished by the contractor (article 49 supplemented)
- Article 36 - Organisation and security of sites (article 50 of GAC)
- Article 37 - Implantation of structures (article 52 of GAC)
- Article 38 - Sub-contracting (article 54 of GAC)
- Article 39 - Site laboratory and trials (article 55 of GAC)
- Article 40 - Site logbook (article 56 of GAC supplemented)
- Article 41 - Use of explosives (article 60 of GAC)

Chapter IV: Acceptance

- Article 42 - Provisional acceptance (article 67 of GAC)
- Article 43 - Documents to be furnished after execution (article 68 of GAC)
- Article 44 - Guarantee time-limit (article 70 of GAC)
- Article 45 - Final acceptance (article 72 of GAC)

Chapter V: Miscellaneous provisions

- Article 45 - Termination of the contract (article 74 of GAC)
- Article 46 - Force majeure (article 75 of GAC)
- Article 47 - Differences and disputes (article 79 of GAC)
- Article 48 - Drafting and dissemination of this contract
- Article 49 and last: Entry into force of the contract

Chapter I: General

Article 1: Subject of contract

The subject of this contract shall be THE CONSTRUCTION OF THREE BRIDGES: THE LOWER MUNJONG BRIDGE (6LM); THE MENYAM BRIDGE (8LM) WITH ACCESS ROADS IN BAMUNKA VILLAGE; AND THE BRIDGE (8LM) ALONG THE NDOP GENERAL HOSPITAL-BAMUNKA PALACE ROAD STRETCH (TRANSFERRED TO NTOCHEW BRIDGE (8LM) AT MBUKEU-MESSI STRETCH OF ROAD) IN NDOP MUNICIPALITY, NGOKETUNJIA DIVISION IN NORTH WEST REGION.

Article 2: Contract award procedure

This contract shall be awarded by Open National Invitation To Tender N°...../ONIT/ MINDDEVEL /NC/NCITB/ROAD FUND/ 2026 OF ,,,/.../ 2026

Article 3: Definitions and duties (article 2 of GAC supplemented)

3.1 General definitions (cf. Code)

- The Contracting Authority shall be the **Lord mayor of NDOP Council**
He awards the contract, ensures the preservation of originals of said contract documents and the transmission of copies to Ministry in charge of Public Contracts and to the body in charge of regulation.
- The Contract Engineer shall be the **Divisional Delegate of Public Works for Ngoketunjia** hereinafter referred to as the Engineer and shall sign the "Attachment"
- The Project **Owner is the Lord Mayor of NDOP Council**. He represents the beneficiary administration of the works.
He ensures respect of the administrative, technical and financial conditions and contractual deadlines.
- **The Project Manager** shall be the **Chief of Technical Service MINTP/Ngoketunjia** herein after referred to as the Follow up Engineer.
He ensures respect of the administrative, technical and financial conditions and contractual deadlines.
- The **Control Brigade of MINMAP** shall carry out regular unannounced control visit to the site to ensure the respect of this jobbing order.
- The contractor shall be [to be specified].

3.2 Security

This contract may be used security subject to any form of transfer of the debt.

In this case:

- The authority in charge of ordering payment shall be the **Lord Mayor of NDOP Council**.
- The authority in charge of the clearance of expenditures shall be the **Accountant of Road Fund**.
- The body or official in charge of payment shall be the **Administrator of Road Fund**.
- The official competent to furnish information within the context of execution of this contract shall be the **Lord Mayor of NDOP Council**.

3.3 Duties of the Control Mission, Project Manager

3.3.1 Missions [to be completed, where need be]

3.3.2 Means put at the disposal of the Control Mission [to be completed where need be].

Article 4: Language, applicable law and regulation

1.4 The language to be used shall be [English and/or French].

1.5 The contractor shall be bound to observe the law, regulations and ordinances in force in Cameroon both within his own organization and in the execution of the contract.

If the laws and regulations in force at the date of signature of this contract are amended after the signature of the contract, the possible direct resulting costs shall be taken into account without gain or loss for either party.

Article 5: Constituent documents of the contract (Article 4 of GAC)

The constituent contractual documents of this contract are in order of priority: (to be adapted to the nature of the works).

- 1) The tender or commitment letter;
- 2) The bidder's tender and its annexes in all provisions not contrary to the Special Administrative Conditions (GAC) and the Special Technical Conditions (STC) hereunder;
- 3) The Special Administrative Conditions (SAC);
- 4) The Special Technical Conditions (STC);
- 5) The particular elements necessary for the determination of the contract price, such as, in order of priority: the unit price schedule, the statement of all-in prices, detailed estimates, the breakdown of all-in prices and the sub-details of unit prices;
- 6) Plans, calculation notes, trial documents, geotechnical documents [insert and indicate, where need be, names and references].
- 7) The General Administrative Conditions applicable on public works contracts that went into effect by Order No. 033/CAB/PM of 13 February 2007;
- 8) The General Technical Condition(s) applicable on the services forming the subject of the contract [insert and indicate, where need be, names and references].

Article 6: General instruments in force

This contract shall be governed by the following general instruments [to be adapted according to the case]:

1. Framework Law No. 96/12 of 5 August 1996 on the management of the environment;
2. The Mining Code;
3. Instruments governing the various professional bodies;
4. Decree No. 2001/048 of 23 February 2001 relating to the setting up, organization and functioning of the Public Contracts Regulatory Agency
5. Decree No. 2003/651/PM of 16 April 2003 to lay down the procedure for implementing the tax and customs system applicable to public contracts;
6. Decree No. 2018/366 of 20 June 2018 to institute the Public Contracts Code;
7. Decree No. 2012/075 of 8 March 2012 to organise the Ministry in charge of Public Contracts;
8. Circular No. 002/CAB/PM of 21 January 2011 relative to the amelioration of the performance of the public contract system;
9. Circular No. 001/CAB/PR of 19 June 2012 relating to the award and control of execution of Public Contracts;
10. Letter No; 00908/MINTP/DR of 1997 to publish guidelines for the consideration of environmental impact of road maintenance;
11. Law No 2024/013 of 23 December 2024 to lay down the Finance Law of the Republic of Cameroon for the financial year 2025
12. Circular No 00013995/C/MINFI of 31 Dec 2024 Bearing instructions relating to the implementation of the finance laws, the monitoring and control of the execution of the budgets of the State and other public entities for the 2025 fiscal year.
13. Law No 2018/012 of 11 July 2018 relating to fiscal regime of the State and other public entities.
14. Law No 2018/011 of 11 July 2018 to lay down the Cameroon Code of transparency and good Governance in public finance management.
15. Circular Letter No 000005/LC/MINMAP/CAB OF 26 Dec 2023 on the implementation of the categorisation of Building and Public Works sector Enterprises within the framework of contracting public contracts.
16. Unified Technical Documents (DTU) for building works;
17. Applicable standards;

Other instruments specific to the domain concerned with the contract

Article 7: Communication (Articles 6 and 10 supplemented)

- 1.1 All communications within the framework of this contract shall be written and notifications sent to the following address:
- a) In the case where the contractor is the addressee: Sir/Madam.....
Beyond the time-limit of 15 days fixed in article 6(1) of the GAC to make his domicile known to the Project Owner and Contract Manager, correspondences shall be validly addressed to the [to the specified] council, chief town of the region in which the work was done;
 - b) In the case where the Project Owner is the addressee:
Sir/Madam_____ [to be specified] with a copy addressed to the Contracting Authority, Contract Manager, Contract Engineer, Project Manager and where need be, within the same deadline.
 - c) In the case where the Contracting Authority is:
Sir/Madam [to be specified] with a copy addressed within the same deadline to the Project Owner, Contract Manager, Contract Engineer and Project Manager, where applicable
- 1.2 The contractor shall address all written notifications or correspondences to the Project Manager with a copy to the Contract Manager.

Article 8: Administrative Orders (Article 8 of GAC)

- 8.1 The Administrative Order to start execution of works shall be signed and notified to the Contractor by the **Contracting Authority/ Project Owner** with a copy to MINMAP, the Contract Manager, Contract Engineer, the Paying Body and the Project Manager, where applicable.
- 8.2 Based on the minutes of a site meeting jointly signed by **Contracting Authority/Project Owner, MINMAP and Project Engineer** Administrative Orders with an incidence on the objective, the amount and execution deadline shall be signed by the **Contracting Authority/Project Owner** and notified by the **Project Engineer** to the Contractor with a copy to the **MINMAP, the Project Manager** and the Paying Body. The prior endorsement of the Paying Body shall possibly be required before the signature of those that have an incidence on the amount.
- 8.3 Administrative Orders of a technical nature linked to the normal progress of the work and without financial incidence shall be signed by the Contracting Authority/ Project owner based on the report of a joint site visit done by Contracting Authority/Project Owner, MINMAP and Project Engineer, and notified to the Contractor by the Contract Engineer with a copy to MINMAP and Project Manager
- 8.4 Administrative Orders serving as warnings shall be signed by the **Contracting Authority/Project Owner** and notified to the Contractor by the **Contract Engineer** with a copy to **MINMAP and Project Manager**.
- 8.5 Administrative Orders for suspension or resumption of work as a result of the weather or any other case of force majeure shall be signed by the **Contracting Authority/Project Owner** and notified to the Contractor by the **Contract Engineer** with a copy to **MINMAP and Project Manager**.
- 8.6 Administrative Orders prescribing works necessary to remedy disorders which could appear on structures during the guarantee period and not related to normal usage shall be signed by the **Project owner** upon the proposal of the **Contract Engineer** and notified to the Contractor by the **Contract Engineer** and a copy sent to **MINMAP and Project Manager**.
- The contractor has a time-limit of **fifteen (15) days** to issue reservations on any Administrative Order received. Having reservations shall not free the enterprise of executing the Administrative Orders received.

Article 9: Contracts with conditional phases (Article 9 of GAC)

- 9.1 [Specify if the contract has one or several phases]
At the end of a phase, the Project Owner shall carry out the acceptance of the works and issue an attestation of proper execution to the contractor. This attestation shall condition the start of the following conditional phase.
- 9.2 The time-limit granted for notification of the Administrative Order to start execution of a conditional phase shall be five (5) days.

Article 10: Contractor's equipment and personnel (Article 15 of GAC supplemented)

- 10.1 Any modification, even partial, made to the technical bid shall only occur after the written approval of the Contract Manager. In case of modification, the contractor shall have himself replaced by a member of staff of equal competence (qualifications and experiences).

- 10.2 In any case, the lists of supervisory staff to be used shall be subject to the approval of the Project Owner in the days following notification of the Administrative Order to start execution. The Project Manager has **5 (five) days** to notify his opinion in writing with a copy sent to the Contract Manager. Beyond this time-limit, the staff list shall be considered as approved.
- 10.3 Any unilateral modification on the supervisory staff made in the technical bid prior to and during the works shall be a reason for termination of the contract as mentioned in article 45 below or the application of penalties [to be specified where need be].

Chapter II: Financial conditions

Article 11 Guarantees and bonds (Articles 29 and 41 of GAC)

11.1 Final bond

The final bond shall be set at 2% of the amount of the contract, inclusive of all taxes.

It is constituted and transmitted to the Contract Manager within a maximum deadline of twenty (20) days of the notification of the contract.

The bond shall be returned or the guarantee released within one month following the date of provisional acceptance of the works, following a release issued by the Contracting Authority upon request by the contractor.

11.2 Performance bond

The retention fund shall be set at 10 % of the amount of the contract, inclusive of all taxes.

The return or release of the retention fund or security shall be done within one month after final acceptance by release issued by the **Contracting Authority** upon request by the contractor.

11.3 Guarantee of start-off advance

20% maximum of the amount of the contract inclusive of all taxes guaranteed at 100%) and conditions for the return of the guarantee

Article 12: Amount of the contract (Articles 18 and 19 of GAC supplemented)

The amount of this contract as indicated by the attached [detail or estimates] is _____ (in figures) _____ (in letters) CFA francs Inclusive of All Taxes; that is:

- Amount exclusive of VAT: _____ (_____) CFA F
- Amount of VAT: _____ (_____) CFA F.
- Amount of TSR and/or _____ CFA F
- Net to be paid= EVAT-TSR and/or AIR

Article 13: Place and method of payment

The Project Owner shall release the sums due in the following manner:

- a. For payments in CFA francs (amount in figures and letters exclusive of taxes) by credit to account No. _____ opened in the name of the contractor in the _____ bank.
- b. For payments in foreign currencies (amount in figures and letters exclusive of taxes) by credit to account No. _____ opened in the name of the contractor in _____ bank.

Article 14: Price variation (Article 20 of GAC)

17.1 Prices shall be firm.

- a. Payments on account made to the contractor as advances shall not be revisable.
- b. Revision shall be "frozen" upon expiry of the contractual time-limit, except in the case of price reductions.

17.2 Price updating modalities (not applicable)

Article 15: Price revision formulae (article 21 of GAC) (not applicable)

Article 16: Price updating formulae (article 21 of the GAC) (not applicable)

Article 17: Works under State supervision (Article 22 of GAC supplemented)

17.1 The percentage of works under State supervision shall be [must not exceed 2 %] of the amount of the contract and its additional clauses, where applicable.

17.2 In the case where the contractor were invited to execute works under State supervision, the submitted and duly justified expenditures shall be reimbursed to him under the following conditions:

- The quantities considered shall be the hours used or the quantities of building materials and materials used that was the subject of joint job cost sheets;
- The remunerations and salaries effectively paid to local labour shall be increased by forty per cent (40 %) to take account of social benefits;
- The hours put in by the heavy equipment shall be counted at the rate featuring in the sub-detail of prices;
- Building materials and materials shall be reimbursed at cost price duly justified at the place of use, marked up by ten per cent for loss, stocking and handling;
- The amount for services thus calculated, including the hours put by heavy equipment shall be marked up by 25 % to take into account the overheads, profits and the contractor's unforeseen.

Article 18: Evaluation of works (article 23 of the GAC)

This contract is at [unit price, all-in price or unit and all-in price].

Article 19: Evaluation of supplies (article 24 of the GAC supplemented)

19.1 [Indicate, where applicable, the modalities for payment of supplies].

19.2 No security shall be requested for payments on account on supplies.

Article 20: Advances (article 28 of the GAC)

20.1 The Contracting Authority may grant a start-off advance equal to 20% of the amount of the contract.

20.2 This advance whose value cannot exceed twenty (20) percent of the initial amount inclusive of all taxes shall be guaranteed at one hundred (100) percent by a banking establishment governed by Cameroon law or a first-rate financial institution in accordance with the instruments in force and reimbursed by deduction of the payments on accounts to be paid to the contractor during the execution of the contract according to the modalities laid down in the Special Administrative Conditions.

20.3 The total amount of the advance must be reimbursed not later than when the value in basic price of the works reaches eighty (75) percent of the amount of the contract.

20.4 As the reimbursement advances, the Project Owner shall issue the release of the corresponding part of the guarantee upon the express request by the contractor.

20.5 The possibility of granting start-off advance or advance for supplies must be expressly stipulated in the Tender File.

Article 21: Payment for works (articles 26, 27 and 30 of the GAC supplemented)

21.1 Establishment of works executed

Before the 30th of each month, the contractor and the Project Manager shall jointly establish a job cost sheet which summarises and fixes the quantities executed and established for each item on the schedule during the month and capable of giving entitlement to payment.

21.2 Monthly detailed account

No later than the fifth (5th) of the month following the month of the services, the contractor shall hand over to the Project Manager two draft provisional monthly detailed accounts in seven copies (one detailed account exclusive of VAT and the other inclusive of taxes), according to the agreed model and establishing the total amount of the sums to which he may lay claim as a result of the execution of the contract since the start of the contract.

Only the detailed account exclusive of VAT shall be paid to the contractor. The detailed account of the amount of the taxes shall be the subject of an entry into the budgets of the Ministry in charge of Finance

Only the amount exclusive of VAT shall be paid to the contractor as follows:

- [(100-2.2%) and/or (100-5.5)%] paid directly into the account of the contractor;
- (2.2 OR 5.5) % paid to the public treasury as AIR due by the contractor.

The Project Manager has a time-limit of seven (7) days to forward to the Contract Manager the detailed accounts he has approved.

The Contract Engineer has a maximum time-limit of twenty-one (21) days to forward the detailed accounts he approved such that they are in his possession not later than the twelfth of the month.

The Contract Manager has a deadline of fourteen (14) days maximum to sign the detailed accounts.

Payments shall be done by _____ within a maximum deadline of _____ calendar days from the date of submission of the approved detailed accounts.

21.3 Detailed account of start-off account (if applicable).

Article 22: Interest on overdue payments (Article 31 of the GAC)

Possible interests on overdue payments are paid by statement of sums due in accordance with article 167 of Decree No. 2018/366 of 20 June 2018 to institute the Public Contracts Code.

Article 23: Penalties (Article 32 of the GAC supplemented)

A. Penalties for delay

23.1 The amount set for penalties for delays shall be set as follows:

- a) One two thousandth (1/2000th) of the initial contract amount all taxes inclusive per calendar day of delay from the first to the 30th day beyond the contractual time-limit;
- b) One thousandth (1/1000th) of the initial amount of the contract inclusive of all taxes per calendar day beyond the 30th day.

23.2 The cumulated amounts of penalties for delay shall be limited to ten percent (10 %) of the initial contract inclusive of all taxes.

B. Specific penalties [amount to be indicated]

23.3 Independently of penalties for overrun of contractual time-limit, the contractor shall be liable for the following special penalties for the non-observation of the provisions of the contract, especially:

- Late submission of final bond;
- Late submission of insurances;
- Late submission of the draft execution schedule if the lateness is caused by the contractor.

Article 24: Payment in case of a group of enterprises (article 33 of the GAC) Not applicable

Article 25: Final detailed account (article 34 of the GAC)

25.1 After completion of the works and within a maximum time-limit of fourteen (14) days after the date of Provisional acceptance, the contractor shall establish, based on joint reports, the draft final detailed account of works executed to the contract Engineer. This final detailed account of works executed summarises the total sums to which the contractor may be entitled as a result of the execution of the whole Jobbing Order.

25.1 The Contract Manager has up to thirty (30) days to notify the corrected and approved draft to the Project Manager.

25.2 The contractor has up to thirty (30) days to return the signed final detailed account.

Article 26: General and final detailed account (article 35 of the GAC)

26.1 The Contract Manager or the Project Manager has up to thirty (30) days to establish the general detailed account and forward to the contractor after final acceptance.

At the end of the guarantee period which results in the final acceptance of the works, the Contract Manager draws up the general and final detailed accounts of the contract which he has had signed jointly by the contractor and the Contracting Authority. This detailed account includes:

- the final detailed account,
- the balance
- the summary of monthly payments on account.

The signing of the general and final detailed account without reservation by the contractor definitely binds the two parties, puts an end to the contract, except with regard to interest on overdue payments.

26.2 The contractor has up to thirty (30) days to return the signed final detailed account.

Article 27: Tax and customs regulations (article 36 of the GAC)

Decree No. 2003/651/PM of 16 April 2003 lays down the terms and conditions for implementing the tax regulations and customs procedures applicable to public contracts. The taxes applicable to this contract include notably:

- Taxes and dues relating to industrial and commercial profits, including the IAR which is a deduction on company taxes;
- Registration dues in accordance with the Tax Code;
- Dues and taxes attached to the execution of services provided for in the contract;
 - o Duties and taxes of entry into Cameroonian territory (customs duties, VAT, computer tax);

- o Council dues and taxes;
- o Dues and taxes relating to the extraction of building materials and water.

These elements must be included in the costs which the undertaking imputes on its running costs and constitute one of the elements of the sub-details of prices exclusive of taxes.

All taxes inclusive prices means VAT included.

Article 28: Stamp duty and registration of contracts (article 37 of GAC)

Seven (7) original copies of the contract shall be stamped by and at the cost of the contractor, in accordance with the applicable regulations.

Chapter III: Execution of works

29 COMMENCEMENT OF WORK:

Before the commencement of work the contractor must be installed on the site by the following:

- ❖ The Authorizing Officer or his representative (President)
- ❖ Contract Engineer (Secretary)
- ❖ The Project Manager or his representative..... (Member)
- ❖ The Divisional Delegate of MINMAP or his representative.....(Member)
- ❖ The Divisional Delegate of MINEPAT or his representative(Member)
- ❖ The CDO of NDOP Council or his Representative.....(Member)
- ❖ The Contractor or his representative.....(Member)

Article 30: Nature of the works (article 46 of GAC)

The works shall include especially: (position or volume of works)

(To be specified cf. Special Technical Conditions)

Article 31: Role and responsibilities of the Project Owner (GAC supplemented)

31.1 The Project Owner shall be bound to furnish the contractor with information necessary for the execution of his mission and to guarantee, at the cost of the contractor, access to sites of projects.

31.2 The Project Owner shall ensure the contractor of protection against threats, insults, violence, assault and battery, slander or defamation of which he could be victim by reason of or during the exercise of his mission.

Article 32: Execution time-limit of the contract (article 38 of the GAC)

32.1 The time-limit for the execution of the works forming the subject of this contract shall be **five (05) months for each phase.**

32.2 This time-limit shall run from the date of notification of the Administrative Order to commence execution of the works.

Article 33: Role and responsibilities of the contractor (article 40 of the CAG)

The detailed and general plan of progress of the works shall be communicated to the Project owner in five (05) copies at the beginning.

Article 34: Provision of documents and site (article 42 of the GAC)

A reproducible copy of the plans featuring in the Tender File shall be submitted by the Contract engineer.

The Project Owner shall make available the site and access ways to the contractor at the appropriate time as the works progress.

Article 35: Insurance of structures and civil liabilities (article 45 of GAC)

The following insurance policies are required within the scope of this jobbing order in the minimum amounts indicated hereafter within fifteen (15) days of the notification of the contract (to be adapted):

- Liability insurance, business manager;
- Comprehensive insurance of the site;
- Insurance covering its ten-year obligation, where applicable.

Article 36: Documents to be furnished by the contractor (Article 49 of the GAC supplemented)

36.1 Programme of works, Quality Assurance Plan and others

a) Within a minimum deadline of [fifteen (15) days] from the date of notification of the Administrative Order to commence execution, the contractor shall submit in [six (6)] copies for the approval of [Project owner after the endorsement of the Contract Engineer] the execution programme of the works, his supply calendar,

his draft Quality Assurance Plan and the Environment Management Plan, where applicable. A duly signed copy of the execution must be deposited at the DD of MINMAP latest 15 (fifteen days) from the date of notification of the Administrative Order to commence execution.

This programme shall be exclusively presented according to the furnished models.

Two (2) copies of these documents will be returned to him within a deadline of fifteen (15) days from the date of reception with:

- Either the indication "GOOD FOR EXECUTION";
- Or the indication of their rejection including the reasons for the said rejection.

The contractor has eight (8) days to present a new draft. The Contract Manager or the Project Manager then has a deadline of five (5) days to give his approval or possibly make comments. Delay in approving the draft execution schedule shall stay the execution deadline.

The approval given by the Project owner does not in any way release the contractor of his responsibilities. Meanwhile, works executed before the approval of the programme shall neither be ascertained nor paid for. The updated and approved schedule will become the contractual schedule.

The contractor shall constantly update on site, a schedule that will take account of real progress of the site. Significant modifications may only be made on the contractual programme upon receiving the approval of the Project owner. After approval of the execution schedule by the project owner, the latter shall transmit it within five (5) days to the Contracting Authority without staying its execution. However, if important modifications alter the objective of the contract or the nature of the works, the Contracting Authority shall return the execution schedule accompanied by reservations to be lifted within fifteen (15) days of the date of reception.

- b) The Environment Management Plan should bring out notably the choice technical conditions of the site and basic life, conditions of the backfill of the extraction sites and conditions for reinstating the works and installation sites.
- c) The contractor shall indicate in this schedule the equipment and methods which he intends to use as well as the personnel he intends to employ.
- d) The approval granted by the Project owner shall in no way diminish the responsibility of the contractor with regard to the harmful consequences which their implementation may cause both towards third parties and the respect of clauses of the contract

36.2 Execution draft

- a) The execution plan documents (calculations and drawings) necessary for the realisation of all the parts of the structure must be submitted for the endorsement of the [Contract Manager or Project Manager] at most fifteen (15) days prior to the date provided for the commencement of execution of the corresponding part of the structure.
- b) The [Contract Engineer or Project owner] has a deadline of [five (05) days] to examine and make known his observations. The contractor then has a deadline of [04] four days] to present a new file including the said observations.

36.3 In case of the non-observance of the approval deadlines of the above documents by the Administration, these documents shall be deemed to have been approved.

Article 37: Organisation and safety of sites (article 50 of the GAC)

37.1 Signboards at the beginning and end of each section must be placed within a maximum deadline of fifteen days after the notification of the Administrative Order to commence work.

37.2 The services to inform in case of interruption of traffic or along the deviated itinerary: [To be specified in accordance with article 50(2) of the GAC].

37.3 Indicate the special measures demanded of the contractor, other than those provided for in the GAC, for rules of hygiene and safety and for circulation around or in the site.

Article 38: Implantation of structures

The Project Manager shall notify within [five] days following the date of notification of the Administrative Order to commence work, the basic points and levels of the project.

Article 39: Sub-contracting (article 54 of the GAC)

There shall be no sub-contracting

Article 40: Site laboratory and trials (article 55 of GAC)

- 40.1 Indicate if necessary the modalities for carrying out the trials and geotechnical studies provided for in the Special Technical Conditions.
- 40.2 The Contract Engineer has a deadline of three days to approve the contractor's personnel and laboratory as soon as the request is made.

Article 41: Site logbook (article 56 of the GAC supplemented)

- 41.1 The Site logbook must be systematically jointly signed by MINMAP and Engineer, where need be and the contractor's representative each day.
- 41.2 It is a joint document in a single copy. Its pages must be numbered and initialled. No page should be removed. The erased or cancelled parts must be mentioned on the margin for validation.
- 41.3 Absence of site log book that is duely signed shall be sanctioned with a penalty of 3,000 (three thousand) F CFA per day

NB the Site logbook must be such that two carbon copies of each page are left behind.

Article 42: Use of explosives (article 60 of the GAC)

Explosives shall not be used during the execution of this job

Chapter IV: Acceptance

Article 43: PROVISIONAL ACCEPTANCE

43.1 PRE- ACCEPTANCE OPERATIONS

Before the acceptance of the works the contractor shall ask in writing to the control Engineer and copy the chief of control brigade MINMAP to organize a technical visit for pre-acceptance. This visit shall include the following operations.

- Qualitative and quantitative evaluations of the different works that have been executed.
- Findings and statement of the unexecuted task envisaged in the present jobbing order.
- Findings relative to the completion of the work
- Findings on the quantity of works that have been effectively realized

These operations shall be subject to a site report drawn up on the field, signed by the following.

- Control Engineer Secretary
- control brigade MINMAP...observer
- Contractor.....member

During this pre-reception, the engineer shall eventually specify the reserves to be lifted and the corresponding works to be effected before the reception. The Engineer shall fix the reception date in collaboration with the chief of service for the contract.

43.2 Acceptance

The acceptance commission shall comprise:

- 1- The Authorizing Officer or his representative (Chairman)
- 2- The Contract Engineer..... (Secretary)
- 3- The Project Manager or his Representative..... (Member)
- 4- The DD MINMAP or his Representative..... (Observer)
- 5- The CDO of NDOP Council or his Representative.....(Member)
- 6- The Contractor or his Representative.....(Member)

The commission shall examine the report of the pre-acceptance and shall proceed to the acceptance. An acceptance report (process - verbal) of the works shall be prepared by the Engineer and sign by all the commission members.

Article 44: GUARANTEE PERIOD.

The guarantee period is one (01) year from the date of the provisional reception for the section of new civil Engineering works.

Article 45: Article 45: Final acceptance (article 72 of the GAC)

- 45.1 Final acceptance shall take place within a maximum deadline of [fifteen (15) days] from the date of expiry of the guarantee.

The procedure for final acceptance shall be the same as for provisional acceptance

Chapter V: Sundry provisions

Article 46: Termination of the contract (article 74 of the GAC)

The contract may be terminated as provided for in article 167 of Decree No. 2018/366 of 20 June 2018 and equally under the conditions laid down in articles 74, 75 and 76 of the GAC especially in one of the following cases:

- Delay of more than fifteen (15) calendar days in the execution of an Administrative Order or unjustified stoppage of more than seven (7) calendar days;
- Delay in work resulting in penalties of more than 10 % of the amount of the works;
- Refusal to repeat poorly executed works;
- Default by the contractor;
- Persistent non-payment for services.

Article 47: Case of force majeure (article 75 of the GAC)

If the contractor were to raise the issue of force majeure, the thresholds below which claims shall not be admitted are:

- Rainfall: 200 millimetres in 24 hours;
- Wind: 40 metres per second;
- Flood: decennial flood frequency.

Article 48: Disagreements and disputes (article 79 of the GAC)

Disagreements and disputes resulting from the execution of this contract may be settled amicably.

Where no amicable solution can be found for a disagreement, it is brought before the competent Cameroonian jurisdiction, subject to the following provisions: [to be filled, where need be].

Article 49: Production and dissemination of this contract

Eight (08) copies of this contract shall be produced at the cost of the contractor and furnished to the Contract Manager.

Article 50 and last: Entry into force of the contract

This contract shall be final only upon its signature by the Contracting Authority. It shall enter into force as soon as it is notified to the contractor by the Contracting Authority.

**Document No. 5:
Special Technical Conditions
(STC)**

SPECIAL TECHNICAL SPECIFICATIONS

TECHNICAL SPECIFICATIONS

1 - GENERALITIES:

This present special technical specifications concern the completion works of CONSTRUCTION WORKS FOR A PERMANENT 6 M REINFORCED CONCRETE BRIDGE IN THE HAUSA QUARTER, INCLUDING THE CONSTRUCTION OF A 2 M × 2 M BOX CULVERT ALONG THE BAMUNKA-NDOP ROAD SECTION; CONSTRUCTION WORKS FOR A PERMANENT 7 M LINEAR REINFORCED CONCRETE BRIDGE OVER THE UPPER KAKE RIVER IN BAMUNKA VILLAGE, ALONG THE BAMUNKA-NDOP ROAD; AND CONSTRUCTION WORKS FOR A PERMANENT 8 M LINEAR REINFORCED CONCRETE BRIDGE OVER THE UPPER MUNJONG RIVER ALONG THE BAMUNKA-NDOP ROAD SECTION IN NDOP MUNICIPALITY, NGOKETUNJIA DIVISION IN NORTH WEST REGION. Contractor to realize the structure as per the execution plans that shall be approved by the competent authority and sample models of equipment and furniture provided by the project owner. Through the Project Engineer, the contractor shall furnish the owner of the project and other project team members within the shortest possible time with an installation plan showing clearly how he intends to run the work site. A fence in local materials shall enclose the whole work site to avoid trespassing.

SIGNPOSTS: The contractor shall put in place at his expense sign-posts indicating work in conformity with the plans put at his disposal by the authority that signed the contract.

Hygiene and safety: The contractor shall ensure total hygiene and security of the site by constructing a temporal pit latrine and putting up a temporal fence around the project site if that be the case. The contractor shall be responsible for the protection of the structures before final reception. He shall be equally responsible for all tools and materials present at the work site. He shall seek an insurance policy to cover theft and fire incidence.

The contractor shall take all preventive measures against accidents. The owner of the project reserves the right to intervene in case of any emergency without necessary interfering with the responsibilities of the contractor. The contractor shall verify all dimensions on the plans. For execution no dimension shall be measured with a scale rule from the plans. The contractor shall check in-situ the possibility of translating the dimensions on plans to the structure before work begins. He shall refer to the Project Engineer in case of any doubt. He shall not on his own modify anything on the structure and shall inform the Project Engineer of any changes that he considers necessary.

All modifications accepted by the contractor shall be accomplished in a specified duration and at his cost without modification of the contract amount. The owner of the project shall have the right to the final choice in case of any modification.

Engineer.

1. General Provisions

1.1 Scope of Works

The works include:

- Clearing, grubbing, and earthworks along the bridge and box culvert footprint.
- Construction of reinforced concrete foundations for bridge abutments and culvert.
- Construction of abutments and wing walls in reinforced concrete.
- Construction of reinforced concrete beams and deck slab for the bridge.
- Construction of 2 m × 2 m reinforced concrete box culvert with wing walls.
- Backfilling, compaction, and finishing works including drainage and surfacing.

The structure shall provide durable service for a minimum design life of 50 years, comply with Cameroon MINTP design and construction standards, and incorporate French/Eurocode reinforced concrete design practices.

1.2 Applicable Standards

MINTP Bridge Design and Construction Manual (latest edition)

NF EN 1990–1992: Eurocodes for structural and concrete design

NF P94-500 / NF P94-100: Foundation and earthwork standards

Cameroon Highway Design Standards (Geometric, Material, and Load Specifications)

ASTM / ISO standards for concrete, steel, and aggregates where applicable

1.3 Definitions and Terms

C25/30, C30/37 concrete: denotes characteristic compressive strength at 28 days in MPa.

B500B reinforcement: high-yield steel bars per NF EN 10080.

Compacted fill: soil or granular material compacted to $\geq 95\%$ Modified Proctor density.

2. Site Preparation and Earthworks

2.1 Clearing and Grubbing

Clear all vegetation, roots, debris, and topsoil within the construction footprint.

Dispose of unsuitable materials in accordance with MINTP environmental guidelines.

2.2 Excavation

Excavate foundation pits, abutments, wing wall trenches, and culvert beds to design elevations.

Side slopes per soil type: 1:1.5 for cohesive soils, 1:2 for granular soils.

Remove soft/organic soils and replace with compacted granular fill.

2.3 Subgrade Preparation

Compact foundation and subgrade soils to $\geq 95\%$ Modified Proctor density.

Apply lime or cement stabilization to unsuitable soils per MINTP guidance.

3. Foundations

3.1 General Requirements

All foundations shall safely transfer vertical and lateral loads.

Concrete footings and piles designed per Eurocode 2 and verified against MINTP loading requirements.

3.2 Spread Footings

Reinforced concrete footings: minimum depth 1.2 m, width per structural calculations.

Concrete: C25/30, vibrated and cured.

Reinforcement: B500B steel bars, minimum 50 mm cover to soil contact.

3.3 Pile Foundations (if required)

Bored reinforced concrete piles: 400–600 mm diameter.

Embedment depth to reach competent bearing stratum.

Reinforcement and concrete as per Eurocode 2 and MINTP design requirements.

4. Abutments and Wing Walls

4.1 Abutments

Reinforced concrete walls cast on completed foundations.

Thickness: 0.4–0.6 m depending on loading.

Reinforcement: vertical and horizontal B500B bars per MINTP structural drawings.

Waterproof back face with bituminous membrane or polymer coating.

Provide weep holes to relieve hydrostatic pressure.

4.2 Wing Walls

Flared or straight reinforced concrete walls: 0.3–0.5 m thick.

Extend ≥ 2 m beyond abutment edges.

Reinforcement per design calculations; include horizontal and vertical bars.

Backfill behind wing walls with granular material in 200–300 mm compacted layers.

Provide slope protection and toe drains if necessary.

5. Superstructure – Beams and Deck Slab

5.1 Beams

I-section or rectangular reinforced concrete beams.

Concrete: C30/37.

Reinforcement: B500B bars, stirrups per structural design.
Camber provided to counter expected live load deflection (5–10 mm).
Minimum concrete cover: 30–40 mm.

5.2 Deck Slab

Cast-in-place reinforced concrete slab: 6 m clear width, 0.2–0.25 m thick.
Reinforcement: steel mesh or bars B500B, monolithic with beams.
Surface: broomed finish for skid resistance.
Expansion joints at abutments using neoprene or bituminous material.

6. Box Culvert – 2 m × 2 m

6.1 General

Reinforced concrete box culvert, C30/37 concrete, B500B steel reinforcement.

6.2 Foundation

Grade beam or spread footing under walls, compacted crushed stone bedding (≥ 200 mm).

6.3 Walls and Slab

Wall thickness: 0.2–0.25 m; top slab 0.25–0.3 m.
Wing walls: reinforced concrete, 0.3–0.5 m thick, to channel water.

6.4 Drainage and Waterproofing

Apply bituminous membrane to exterior surfaces.
Install weep holes or sub-drains behind abutments and wing walls.

7. Backfilling and Compaction

7.1 Material

Well-graded granular material, free from organic matter.

7.2 Placement

Layer thickness: 200–300 mm.
Compaction: $\geq 95\%$ Modified Proctor.
Avoid heavy equipment on fresh concrete until 28-day curing achieved.

7.3 Drainage

Provide minimum 2% slope away from structure.
Use filter layers or drainage pipes behind abutments if necessary.

8. Concrete Works

8.1 Mixing and Placing

Concrete slump: 80–120 mm.
Continuous placement to avoid cold joints; vibrate adequately.

8.2 Curing

Minimum 7 days using wet burlap, water spray, or curing compounds.
Protect against sun, wind, and rain.

8.3 Quality Control

Compressive strength tests: 7, 14, 28 days.
Reinforcement positioning, concrete cover, and curing must be verified.

9. Safety and Environmental Management

Comply with Cameroon MINTP safety and environmental regulations.
Implement erosion, sediment, and dust control.
Maintain traffic safety along Bamunka–Ndop road.

10. Measurement and Payment

Concrete: measured in m^3 , steel reinforcement in tons, backfill in m^3 .
Unit rates include materials, labor, and equipment.
Payments based on completed works, verified by site engineer.

**Document No. 7:
Schedule of Unit Prices**

UNIT PRICE SCHEDULE FOR THE "CONSTRUCTION DU PONT EN BÉTON DÉFINITIF DE 6M METRE
 QUARTIER HAUSA ET LE GNPS AVEC CONSTRUCTION D'UN DALOT DE 2X2 M SUR LE TRANÇON DE ROUTE
 BAMUNKA -NDOP DANS LA COMMUNE DE NDOP DÉPARTEMENTAL DU NGOKETUNJIA REGION DU NORD
 OUEST

No	DESCRIPTION	UNIT	UNIT PRICE IN FIGURES (FCFA)	UNIT PRICE IN WORDS (FCFA)
100	SITE INSTALLATION			
101	Site clearance	Ls		
102	Setting out of bridge structure	Ls		
103	Execution program and as built plan	Ls		
104	Geotechnical studies / structural analysis	Ls		
	SUB-TOTAL 100			
CONSTRUCTION DU PONT EN BÉTON DÉFINITIF DE 6M METRE QUARTIER HAUSA				
200	EARTHWORKS			
201	General Excavation	m ³		
202	Filling and compacting of later ate from borrow pit on to approaches complete	m ³		
203	Excavation of foundation trenches on earth and in riverbed	m ³		
204	Excavation of foundation trenches on rocky soil	m ³		
205	Filtration materials behind the bridge abutments	m ³		
	SUB-TOTAL 200			
300	Foundation, Abutments, piers, beams, deck Slab			
301	Placing of hardcores of 20cm thick	m ³		
302	Lean concrete dose at 250 kg/m ³ of 10cm thick	m ³		
303	Reinforced concrete dose at 400kg/m ³ abutment, footing, Deck, krebs and conics	m ³		
304	Ordinary formwork	m ²		
305	Special formwork	m ²		
306	Scaffolding	Ls		
	SUB-TOTAL 300			
500	PAINTING			
501	Purchasing and placing of anti rust on metal elements	m ²		
502	Purchasing and placing of oil paint on metal element	m ²		
503	Painting of abutments and wingwalls with bitumen	m ²		
	SUB-TOTAL 500			
600	EQUIPMENTS			
601	Hand rails (Concrete pillars plus Metal poles)	ml		
602	Triangular signalisation boards A or AB	U		
603	Indicator boards	U		

605	Weep holes for abutments	U		
606	Drainage pipes on deck slab	U		
607	Bridge bearings	U		
	SUB-TOTAL 600			
700	CIRCULATION			
701	Maintaining circulation	Ls		
	SUB-TOTAL 700			
CONSTRUCTION D'UN DALOT DE 2X2 M SUR LE TRANÇON DE ROUTE BAMUNKA -NDOP				
EARTH WORKS				
20 1	Excavation of trenches	m3		
20 3	Backfilling of culvert	m3		
20 3	Moulding of the road of 500ml on both side of culvert and creation of ditches	Km		
20 4	Placing of wearing course of 15cm 500ml on both side of culvert selected with Laterite from Borrowed pit	m ²		
	Sub- total Earth works			
CONSTRUCTION WORKS				
30 1	Blinding concrete	m3		
30 2	Hard core	m ³		
30 3	concreting of culvert with concrete dosed at 350kg/m3	m3		
30 4	Formwork	m ²		
30 5	wheepholes	u		
	Sub- total CONSTRUCTION WORKS			
	TOTAL HORS TAXE			
	GENERAL TOTAL CONSTRUCTION DU PONT EN BÉTON DÉFINITIF DE 6M METRE QUARTIER HAUSA ET LE GNPS AVEC CONSTRUCTION D'UN DALOT DE 2X2			
	GENERAL TOTAL WITHOUT TAXES			
	VAT(19.25%)			
	AIR (2.2% or 5.5%)			
	TOTAL ALL TAXES			
	NET TO BE PAID			
<p>UNIT PRICE SCHEDULE FOR THE "CONSTRUCTION DU PONT EN BÉTON DÉFINITIF DE 7ML METRE SUR LE RIVIÈRE UPPER KAKE DANS LE VILLAGE BAMUNKA -NDOP DANS LA COMMUNE DE NDOP DÉPARTEMENTAL DU NGOKETUNJIA REGION DU NORD OUEST "</p>				
No	DESCRIPTION	UN IT	U. PRICE	AMOUNT
100	SITE INSTALLATION			
101	Site clearance	Ls		
102	Setting out of bridge structure	Ls		
103	Execution program and as built plan	Ls		
104	Geotechnical studies Geotechnical and studies / structural analysis	Ls		
	SUB-TOTAL 100			

200	EARTHWORKS			
201	General Excavation	m ³		
202	Filling and compacting of later ate from borrow pit on to approaches complete	m ³		
203	Excavation of foundation trenches on earth and in river bed	m ³		
204	Excavation of foundation trenches on rocky soil	m ³		
205	Filtration materials behind the bridge abutments	m ³		
	SUB-TOTAL 200			
300	Foundation, Abutments, piers, beams, deck Slab			
301	Placing of hardcore of 20cm thick	m ³		
302	Lean concrete dose at 250 kg/m ³ of 10cm thick	m ³		
303	Reinforced concrete dose at 400kg/m ³ abutment, footing, Deck, krebs and conics	m ³		
304	Ordinary formwork	m ²		
305	Special formwork	m ²		
306	Scaffolding	Ls		
	SUB-TOTAL 300			
500	PAINTING			
501	Purchasing and placing of anti rust on metal elements	m ²		
502	Purchasing and placing of oil paint on metal element	m ²		
503	Painting of abutments and wingwalls with bitumen	m ²		
	SUB-TOTAL 500			
600	EQUIPMENTS			
601	Hand rails (Concrete pillars plus Metal poles)	ml		
602	Triangular signalisation boards A or AB	U		
603	Indicator boards	U		
605	Weep holes for abutments	U		
606	Drainage pipes on deck slab	U		
607	Bridge bearings	U		
	SUB-TOTAL 600			
700	CIRCULATION			
701	Maintaining circulation	Ls		
	SUB-TOTAL 700			

UNIT PRICE SCHEDULE FOR THE "CONSTRUCTION DU PONT EN BÉTON DÉFINITIF DE 8ML METRE SUR LE RIVIÈRE UPPER MUNJONG SUR LE TRANÇON DE ROUTE BAMUNKA -NDOP DANS LA COMMUNE DE NDOP DÉPARTEMENTAL DU NGOKETUNJIA REGION DU NORD "

No	DESCRIPTION	UNIT	U. PRICE	AMOUNT
100	SITE INSTALLATION			
101	Site clearance	Ls		
102	Setting out of bridge structure	Ls		
103	Execution program and as built plan	Ls		
104	Geotechnical studies / structural analysis	Ls		
	SUB-TOTAL 100			
200	EARTHWORKS			

201	General Excavation	m ³		
202	Filling and compacting of later ate from borrow pit on to approaches complete	m ³		
203	Excavation of foundation trenches on earth and in river bed	m ³		
204	Excavation of foundation trenches on rocky soil	m ³		
205	Filtration materials behind the bridge abutments	m ³		
	SUB-TOTAL 200			
300	Foundation, Abutments, piers, beams, deck Slab			
301	Placing of hardcores of 20cm thick	m ³		
302	Lean concrete dose at 250 kg/m ³ of 10cm thick	m ³		
303	Reinforced concrete dose at 400kg/m ³ abutment, footing, Deck, krebs and conics	m ³		
304	Ordinary formwork	m ²		
305	Special formwork	m ²		
306	Scaffolding	Ls		
	SUB-TOTAL 300			
500	PAINTING			
501	Purchasing and placing of anti rust on metal elements	m ²		
502	Purchasing and placing of oil paint on metal element	m ²		
503	Painting of abutments and wingwalls with bitumen	m ²		
	SUB-TOTAL 500			
600	EQUIPMENTS			
601	Hand rails (Concrete pillars plus Metal poles)	ml		
602	Triangular signalisation boards A or AB	U		
603	Indicator boards	U		
605	Weep holes for abutments	U		
606	Drainage pipes on deck slab	U		
607	Bridge bearings	U		
	SUB-TOTAL 600			
700	CIRCULATION			
701	Maintaining circulation	Ls		
	SUB-TOTAL 700			

**Document No. 8:
Bill of Quantities and
Estimates**

Document No. 9:
Schedule of sub-detail of prices

Format Schedule of sub-detail of prices

DESIGNATION :					
No	Daily out put		Total quantity	Unit	Duration of activity
WORKMAN SHIP	Category	No	Daily wage	Days break up	Amount
	TOTAL A				
EQUIPMENT/MECHINES	Type	No	Daily rate	Days break up	Amount
TOTAL B					
MATERIAL AND MISCELLANOUS	Type	Unit	Unit cost	Quantity	Amount

	TOTAL C			
D	DIRECT TOTAL COST		A+B+C	
E	GENERAL SITE EXPENSESES		Dx%	
F	GENERAL OFFICE EXPENSES		Dx%	
G	NET COST		D+E+F	
H	RISK + BENEFITS		Gx%	
P	TOTAL COST (HT)		G+H	
V	UNIT COST (HT)		P/Q'TY	

Document No. 10:

Model contract

REPUBLIQUE DU CAMEROUN
Paix-Travail-Patrie
.....
MINISTRE DE LA DÉCENTRALISATION
ET DU DEVELOPPEMENT LOCAL
.....
DELEGATION REGIONALE DU NORD OUEST
.....
DEPARTEMENT DE NGOKETUNJIA
.....
ARRONDISSEMENT DE NDOP
.....
COMMUNE DE NDOP
.....
SERVICE DE PASSATION DES
MARCHES PUBLICS



REPUBLIC OF CAMEROON
Peace-Work-Fatherland
.....
MINISTRY OF DECENTRALISATION
AND LOCAL DEVELOPMENT
.....
NORTH WEST REGIONAL DELEGATION
.....
NGOKETUNJIA DIVISION
.....
NDOP SUB-DIVISION
.....
NDOP COUNCIL
.....
SERVICE FOR THE AWARD OF PUBLIC
CONTRACTS

CONTRACT No___/C/MINDDEVEL/BC/BCITB/BIPMINTP / 2026 OF .../.../ 2026 AWARDED AFTER OPEN
NATIONAL INVITATION TO TENDER BY EMERGENCY PROCEDURE
N°/ONIT/MINDDEVEL/NC/NCITB/BIPMINTP/ 2026 OF FOR THE CONSTRUCTION WORKS FOR A
PERMANENT 6 M REINFORCED CONCRETE BRIDGE IN THE HAUSA QUARTER, INCLUDING THE
CONSTRUCTION OF A 2 M × 2 M BOX CULVERT ALONG THE BAMUNKA-NDOP ROAD SECTION;
CONSTRUCTION WORKS FOR A PERMANENT 7 M LINEAR REINFORCED CONCRETE BRIDGE OVER THE
UPPER KAKE RIVER IN BAMUNKA VILLAGE, ALONG THE BAMUNKA-NDOP ROAD; AND CONSTRUCTION
WORKS FOR A PERMANENT 8 M LINEAR REINFORCED CONCRETE BRIDGE OVER THE UPPER MUNJONG
RIVER ALONG THE BAMUNKA-NDOP ROAD SECTION IN NDOP MUNICIPALITY, NGOKETUNJIA DIVISION
IN NORTH WEST REGION

Project Owner [Indicate name and full address]

HOLDER : [indicate name and full address of holder]

P.O. Box_____, Tel:_____Fax: _____

Business Registry No._____at
Taxpayer's No._____

SUBJECT : Execution of _____ works;
Lot No. _____; Network _____

PLACE : Region _____

EXECUTION DEADLINE : _____ (____) months

AMOUNT IN CFA F:

IAT	
EVAT	
VAT	
AIR (Income tax)	
Net to be paid	

FINANCING : MINTP ROAD FUND 2026 & 2027

BUDGET HEAD :

SUBSCRIBED ON: _____

SIGNED ON: _____

NOTIFIED ON: _____

REGISTERED ON: _____

Between:

The NDOP Council, represented by the Lord Mayor NDOP Council hereinafter referred to the "Contracting Authority"

On the one hand,

And

_____(enterprise)
P.O. Box _____ Tel: _____ Fax: _____
Business Registry No. _____
Taxpayer's No. _____

Represented by M _____, its General Manager, hereinafter referred to as the "Contractor"

On the other hand,

Agree on the following:

Summary

Part I: Special Administrative Conditions (SAC)

Part II: Special Technical Conditions (STC)

Part III: Schedule of Unit Prices (SUP)

Part IV: Details or Estimates

Page _____ and last of Contract No. _____ /C/CA/TB/ 2025

Awarded after invitation to tender [specify references of invitation to tender]

With _____,

For the execution of _____ works

EXECUTION DEADLINE _____ (____) months

Amount of contract in CFA F:

IAT	
EVAT	
VAT (19.25%)	
AIR (2.2 or 5.5 %)	
Net to be paid	

Read and accepted by the contractor

(place of signature) _____ (date)

Signature of Contracting Authority

(place of signature) _____ (date)

Registration

Document No. 11:

Forms and models to be used by bidders

Table of models

Annex No. 1: Model Declaration of intention to tender

Annex No. 2: Model tender

Annex No. 3: Model bid bond

Model No. 4: Model final bond

Model No. 5: Model of start-off advance bond

Model No. 6: Model retention fund

Annex No. 7: Evaluation grid

Annex No. 8: Attestation of site visit

Annex No 9: Site Visit Report

Annex No. 1: Model Declaration of intention to tender

I the undersigned.....acting in the capacity of in the name and on behalf of atRC No by virtue of the power vested in me , domiciled at P.O BOX Telephone no after having studied all the documents of the tender file relating to the invitation to tender N°/ONIT/MINDDEVEL/NC/NCITB/BIPMINTP/ 2026 OF 31/12/2025 And after having assessed in my point of view and under my responsibility the nature and difficulties entailed with the execution of the job, I do hereby tender and commit myself to carry out works for FOR THE CONSTRUCTION WORKS FOR A PERMANENT 6 M REINFORCED CONCRETE BRIDGE IN THE HAUSA QUARTER, INCLUDING THE CONSTRUCTION OF A 2 M × 2 M BOX CULVERT ALONG THE BAMUNKA-NDOP ROAD SECTION; CONSTRUCTION WORKS FOR A PERMANENT 7 M LINEAR REINFORCED CONCRETE BRIDGE OVER THE UPPER KAKE RIVER IN BAMUNKA VILLAGE, ALONG THE BAMUNKA-NDOP ROAD; AND CONSTRUCTION WORKS FOR A PERMANENT 8 M LINEAR REINFORCED CONCRETE BRIDGE OVER THE UPPER MUNJONG RIVER ALONG THE BAMUNKA-NDOP ROAD SECTION IN NDOP MUNICIPALITY, NGOKETUNJIA DIVISION IN NORTH WEST REGION. In keeping with the terms and conditions of the tender fill.

I commit myself in case my tender is retained, to execute the contract within Months as from the date of notification of award of the contract.

I hereby commit myself to maintain the amount of my tender for a period of ninety (90) days with effect from the dateline for submission of bids.

Done at..... On

GENERAL DIRECTOR

Signature.....

Annex No. 2: Model tender

I, the undersigned _____ [indicate the name and capacity of signatory]
Representing the _____ company or enterprise or group with head office at _____ registered in the
trade register of _____ under the number No _____

Having taken cognisance of all the documents featured or mentioned in the Tender File including the
addendum (addenda): the invitation to tender [recall the subject of the invitation to tender]

After having personally taken account of the situation of the site and evaluated from my point of view and
under my responsibility, the nature and difficulty of the works to be carried out;

Hereby submit, bearing my signature, the schedule of unit prices as well as the quotations in accordance with
the structure featuring in the Tender File.

Submit and commit myself to execute the works in accordance with the Tender File, in return for the prices
which I myself establish for each type of structure which prices reveal the amount of the tender for lot No.

_____ at _____ [in figures and words] CFA francs exclusive of VAT and at _____ CFA francs
Inclusive of all Taxes. [In figures and words].

I pledge to execute the works within a deadline ofmonths.

I pledge to maintain my bid for [indicate duration of validity, in principle 90days for national invitations to
tender 120 days for international invitations to tender] from the deadline of submission of bids.

Rebates and the modalities of application the said rebates shall be the following (in case of the possibility of
award of several lots).

The Project Owner shall pay the sums due for this contract by crediting account No..... opened
in.....Bank.....Branch

Prior to the signing of the contract, this tender accepted by you shall constitute an agreement between us.

Done at..... on.....

Signature of.....

in the capacity of.....duly authorised to sign the bids on behalf of.....

ANNEX No. 3: MODEL BID BOND

Addressed to [indicate the Contracting Authority and his address] "Contracting Authority"

Whereas the undertaking _____ hereinafter referred to as the "bidder" has submitted his bid on _____ for [recall the subject of the invitation to tender], hereinafter referred to as "the bid" and to which must be attached a bid bond equivalent to [indicate the amount] CFA francs.

We _____ [name and address of the bank], represented by _____ [names of signatories], hereinafter referred to as "the bank" hereby guarantee payment to the Contracting Authority of the maximum sum of [indicate the amount] CFA francs, that the bank pledges to pay in full to the Contracting Authority, binding itself, its successors and assignees.

The conditions of this commitment are as follows:

If the bidder retires his bid during the validity period provided for in the Tender File;

Or

If the bidder, having been notified of the award of the contract by the Contracting Authority during the validity period:

Fails or refuses to sign the contract, even though required to do so;

Fails or refuses to furnish the final bond for the contract (final bond) as provided for by the contract;

We pledge to pay to the [Contracting Authority] an amount up to the maximum of the sum referred to above upon reception of the his first written request, without the Contracting Authority having to justify his request, given, however, that in his request the Contracting Authority shall note that he is due the amount he is claiming because one or the other or both of the above condition(s) has (have) been fulfilled and he shall specify which condition(s) took effect.

This bond shall enter into force from the date of signature and from the date set by the Contracting Authority for the submission of bids. It shall remain valid up till the thirtieth day inclusive following the end of the deadline for the validity of bids. Any request by the Contracting Authority to cause it to take effect should reach the bank by registered mail with an acknowledgement of receipt before the end of this period of validity.

This bond shall, for purposes of its interpretation and execution, be subject to Cameroon law. Cameroon courts shall be the only jurisdictions competent to rule on this commitment and its consequences.

Signed and authenticated by the bank at _____, on _____

[Bank's signature]

Annex No. 4: Model final bond

Bank:

Reference of the bond: No _____

Addressed to [Indicate the Project Owner and his address] Cameroon, hereinafter referred to as the "Project Owner"

Whereas _____ [name and address of Contractor], hereafter referred to as "the Contractor", has committed himself, in execution of the contract referred to as "the contract", to carry out [indicate the nature of the works].

Whereas it is stated in the contract that the Contractor shall entrust to the Project Owner a final bond of an amount equal to [indicate the percentage between 2 and 5%] of the amount of the corresponding portion of the contract, as guarantee of the execution of his full obligations in accordance with the terms of the contract,

Whereas we have agreed to issue the Contractor this guarantee,

We, _____ [name and address of bank]
represented by _____ [name of signatories],
hereinafter referred to as "the bank", commit ourselves to pay the Project Owner, within a maximum deadline of eight (8) weeks, upon the simple written request declaring that the Contractor has not satisfied his contractual commitments within the meaning of the contract, without being able to defer the payment nor raise any contests for whatever reason, any sum up to the sum of _____ [in figures and words].

We agree that no change or addendum or any other amendment to the contract shall free us of any obligation incumbent on us by virtue of this final bond and we hereby incline to any notification, addendum or change.

This final bond shall enter into force upon signature and notification of the contract. It shall be released within a deadline of [indicate the deadline] from the date of the provisional acceptance of the works.

After this date, the bond shall be baseless and should be returned to us without the express request on our part.

Any request for payment made by the Project Owner by virtue of this guarantee should be done by registered mail with acknowledgement of receipt to reach the bank during the period of validity of this commitment.

This bond shall, for purposes of its interpretation, be subject to Cameroon law. Cameroon courts shall be the only jurisdictions competent to rule on this commitment and its consequences.

Signed and authenticated by the bank at _____ on _____

[Signature of the bank]

ANNEX No. 5: Model of start-off advance bond

Bank: reference, address _____

We, the undersigned, (bank, address) hereby declare by the present to guarantee on behalf of _____ [the holder] to the benefit of the Project Owner [address of the Project Owner]
(the beneficiary)

The payment, without contest and upon receipt of the first written request by the beneficiary, declaring that _____ [the holder] has not fulfilled his obligations relating to the reimbursement of the start-off advance according to the terms of contract No. _____ of _____ relating to _____ works [indicate the subject of the works, the references of the invitation to tender and the lot, if possible] of the total sum corresponding to the advance of [twenty (20) %] of the amount inclusive of all taxes of contract No. _____, payable upon notification of the corresponding Administrative Order that is, _____ CFA francs.

This bond shall enter into force and shall take effect upon reception of the respective parts of this advance into the accounts of _____ [the holder] opened in the _____ bank under No. _____.

This bond shall remain in force up till the reimbursement of the advance in accordance with the SAC. However, the amount of the bond shall be proportionately reduced on the progressive reimbursement of the advance.

The applicable law and jurisdiction shall be those of the Republic of Cameroon.

Signed and authenticated by the bank at _____ on _____

[Signature of the bank]

ANNEX No. 6: Model of performance bond (Retention fund)

Bank: _____

Reference of the bond: No _____

Addressed to [Indicate the Project Owner]
[Address of Contracting Authority]

Hereinafter referred to as "the Project Owner"

Whereas _____ name and address of Supplier] hereinafter referred to "the contractor", pledged, in execution of the contract, to carry out the works of [indicate the subject of the works]

Whereas it is stipulated in the contract that the retention fund fixed at [percentage below 10 % to be specified] of the amount of the contract may be replaced by a joint guarantee,

Whereas we have agreed to provide the Contractor with this guarantee,
We, _____ [name and address of the bank],
Represented by _____ [names of signatories] and hereinafter referred to as "the bank",

Hence, we hereby affirm that on behalf of the Contractor, we guarantee and are responsible to the Project Owner for a maximum amount of _____
[in figures and letters] corresponding to [percentage below 10 % to be specified] of the contract price.

And we pledge to pay to the Project Owner within a maximum deadline of eight (8) weeks upon his simple written request declaring that the contractor has not fulfilled his contractual obligations or is indebted to the Project Owner within the meaning of the contract, amended where need be, by its additional clauses, without being able to defer the payment nor raise any contest for whatever reason, any sum(s) within the limits of the amount equal to [percentage below 10 % to be specified] of the total amount of the works featuring in the final detailed account, without the Project Owner having to prove or give the reasons nor the motive for the amount of the sum indicated above.

We hereby agree that no change or addendum or any other amendment shall release us of any obligation incumbent on us by virtue of this bond and we hereby incline by the present to the notification of any amendment, addendum or change.

This bond shall enter into force upon signature. It shall be released within thirty (30) days from the date of the final acceptance of the works and upon release issued by the Project Owner.

Any request for payment made by the Project Owner by virtue of this bond should be done by registered mail with acknowledgement of receipt to reach the bank during the period of validity of this commitment. This bond shall, for purposes of its interpretation and execution, be subject to Cameroon law. Cameroon courts shall be the only jurisdictions competent to rule on this pledge and its consequences.

Signed and authenticated by the bank at _____ on _____

[Signature of the bank]

ANNEX 8: EVALUATION GRID

TENDER FILE N°/ONIT/MINDDEVEL/NC/NCITB/BIPMINTP / 2026 OF FOR THE CONSTRUCTION WORKS FOR A PERMANENT 6 M REINFORCED CONCRETE BRIDGE IN THE HAUSA QUARTER, INCLUDING THE CONSTRUCTION OF A 2 M × 2 M BOX CULVERT ALONG THE BAMUNKA-NDOP ROAD SECTION; CONSTRUCTION WORKS FOR A PERMANENT 7 M LINEAR REINFORCED CONCRETE BRIDGE OVER THE UPPER KAKE RIVER IN BAMUNKA VILLAGE, ALONG THE BAMUNKA-NDOP ROAD; AND CONSTRUCTION WORKS FOR A PERMANENT 8 M LINEAR REINFORCED CONCRETE BRIDGE OVER THE UPPER MUNJONG RIVER ALONG THE BAMUNKA-NDOP ROAD SECTION IN NDOP MUNICIPALITY, NGOKETUNJIA DIVISION IN NORTH WEST REGION.

NAME OF BIDDER: _____

ADMINISTRATIVE DOCUMENTS.

DOCUMENT N°	DESCRIPTION	YES	NO
A.1	Declaration of intention to tender stamped with the tariff in force		
A.2	Certified Copy of the Business Registration, not more than three months old.		
A.3	Certificate of non-bankruptcy established by the Court of 1st instance or the Chamber Commerce, Industry and Trade of the place of residence of the bidder, not more than three (03) months.		
A.4	Attestation of bank account of the bidder, issued by a first rate-bank or an insurance company approved by the Ministry in charge of Finance or by a foreign bank the first order not more than three months.		
A.5	Purchase receipt of tender file issued by NDOP municipal treasury		
A.6	A bid bond of four million (4,000,000) FCFA issued in line with the prescriptions of the "Caisse des Depots Et Consignations-CDEC" by a first rate-bank or an insurance company approved by the Ministry in charge of Finance in conformity with COBAC conditions.		
A.7	An attestation of non-exclusion from Public Contracts issued by the Public contract Regulatory Board (ARMP)		
A.8	An Attestation of the National Social Insurance Fund stating that the bidder has met all his obligations vis a vis the Fund; the attestation should be less than three months old.		
A.9	Certified Copy of a valid taxpayers card, delivered by the chief of center of Taxes.		
A.10	A Certificate of tax compliance attesting that the bidder has met all the statutory declarations in issues of taxes in the current financial year; this certificate should be less than three months old.		
A.11	Certified copy of certificate of categorization in the Road Sub-Sector (Category D enterprises only as per Circular Letter No 000005/LC/MINMAP/CAB OF 26 Dec 2023 on the implementation of the categorisation of Building and Public Works sector Enterprises within the framework of contracting public contracts)		
A.12	Plan of localization		

During the opening session of the bids if a document of the administrative bid is absent or noncompliant, the bidder will be given forty-eight (48) hours to produce or replace the said document else it will be eliminated during the evaluation of the bids. No such document will be accepted after this deadline.

The second Internal Envelope shall be labeled <<ENVELOPE B: TECHNICAL DOCUMENT>> and shall contain the following:

B.1	General presentation of the tender files	YES	NO
B.1.1	-Document spirally bound -Table of content page		
B.1.2	-Colour sheets separation - Presentation of documents in the order given in this tender		
B.2	LIST OF REFERENCES OF THE ENTERPRISE IN THE SIMILAR JOBS		
B.2.1	List of references of the enterprise in similar jobs justified by signed contracts of at least sixty million (60,000,000) FCFA (first, and last pages including the bill of quantities) and minutes of reception or attestation of clearances of works executed. Minimum acceptable: 02 Contracts realized in the domain of Road Sub-Sector over the past 05 years		
	1st Reference		
	2nd reference		
B.3	QUALIFICATION AND EXPERIENCE OF SUPERVISORY STAFF		
B.3.1	01 works supervisor (at least civil or rural engineer or equivalent certificate)		
	Qualification of the works supervisor: (Civil or rural Engineering certificate (BAC +3) Professional experience of the project engineer ≥ 03 years (signed CV)		
	<ul style="list-style-type: none"> ➤ A certified copy of the technical diploma, ➤ Certified copy of ID card 		
	<ul style="list-style-type: none"> ➤ An Attestation of presentation of original of the technical diploma ➤ CV signed by the candidate, ➤ Commitment of availability 		
B.3.2	Site foreman (Civil Engineering Senior Technician)		
	Qualification of the Site foreman: (Senior Technician certificate in Civil Engineering (HND or equivalent certificate) Professional experience of the Site foreman ≥ 03 years (signed CV)		
	<ul style="list-style-type: none"> ➤ A certified copy of the technical diploma, ➤ Certified copy of ID card 		
	<ul style="list-style-type: none"> ➤ An Attestation of presentation of original of the technical diploma ➤ CV signed by the candidate, ➤ Commitment of availability 		
B.3.3	Chief Builder		
	Qualification of Chief Builder: (CAP certificate or equivalent) Professional experience >03years (certified copy of the technical diploma and signed CV only)		
B.3.4	Chief Carpenter		
	Qualification of Chief carpentry : (CAP certificate or equivalent) Professional experience >03years (certified copy of the technical diploma and signed CV only)		
B.4	TECHNICAL PROPOSALS		
B.4.1	Organigram of the project (Specify names of the personnel handling the various functions)		
B.4.2	Logical sequence for the execution of the task		
B.4.3	Organization of works/methodology		
B.4.4	Quality control method		

B.4.5	Environmental protection measures		
B.4.6	Security and safety at the site		
B.4.7	Planning of execution of works.		
B.5	LOGISTICS (Equipment put aside for this project)		
B.5.1	Proof of ownership or rental of a pick-up or other vans		
B.5.2	Proof of ownership or rental of a dump truck		
B.5.3	Proof of ownership or rental of a concrete vibrator		
B.5.4	Proof of ownership or rental of a concrete mixer		
B.5.5	Proof of ownership or rental of a Hand compactor		
B.5.6	Masonry Kit : Wheelbarrows, masonry clamps, masonry harmer 300g, shovel, dig axe, building level, masonry bucket , trowels, etc.		
B.5.7	Carpentry Kit : carpentry clamps, saws, harmers, etc.		
B.6	FINANCIAL CAPACITY		
B.6.1	An attestation of financial capacity (solvency) of the enterprise issued by a 1st class bank located in any area in Cameroon and approved by the Ministry of Finance and respect COBAC conditions. 75% of the project amount		
B.7	Attestation of site visit signed by the director of the Company on honour		
B.8	Comprehensive report of site visit signed by the company administrator and justified by photos		
B.9	Special Technical Clauses initialed in all the pages and last page signed and dated with the following note: Read and approved		
B.10	Special Administrative Clauses completed and initialed in all the pages and last page signed and dated with the following note: Read and approved		

ENVELOPE C- FINANCIAL FILE

No.	DESIGNATION.	YES	NO
C1	A submission letter, signed, dated and stamped.		
C2	Completed and signed frame work of unit prices.		
C3	Signed Bills of quantities and cost estimates indicating the total amount without taxes (HT) and with taxes (TTC)		
C4	Sub details of unit prices		

This evaluation will be done in a purely positive way (yes) or negative (no) with an acceptable minimum from at least 75% of the essential criteria taken in account.

The contract will be awarded to the bidder who would have proposed the offer with the lowest amount, in conformity with the regulations of the Tender Documents and having satisfied to 100% of the eliminatory criteria and at least 75% of the essential criteria.

Eliminatory criteria

- 1- 1. Absence or insufficient bid bond (outright elimination);
2. Absence or non-conformity of a document in the administrative file
3. False declaration or falsified documents;
4. Incomplete financial file;
5. Omission of a unit price in the financial bid;
6. Deadline for delivery higher than prescribed;
7. Non respect of 75% of essential criteria;
8. External envelope carrying a sign that can identify the bidder;

Essential criteria

- General presentation of the bids;
- Financial capacity;
- References of the company in similar achievements;
- Quality of the personnel;
- Technical organization of the works;
- Logistics;
- Special Technical Clauses initialed in all the pages and signed on the last page;
- Special Administrative Clauses completed and initialed in all the pages and signed on the last page.

11. Main qualification criteria

The criteria relating to the qualification of candidates could be indicative on the following:
 The essential criteria are subjected to minima whose detail is given in the Special Tender Regulation (RPAO).
 This evaluation will be done in a purely positive way (yes) or negative (no) with an acceptable minimum from at least 75% of the essential criteria taken in account.
 The contract will be awarded to the bidder who would have proposed the offer with the lowest amount, in conformity with the regulations of the Tender Documents and having satisfied to 100% of the eliminatory criteria and at least 75% of the essential criteria.

ANNEX 7: MODEL ATTESTATION OF SITE VISIT

I the undersigned Mr./Mrs./Miss[Surname and Name of Director]The Director of [Name of company] confirm that Mr./Mrs./Miss (Surname and Name)

Engineer of my Company: (Name of Enterprise),
 has actually visited the site which is going to receive the structure relative to OPEN NATIONAL INVITATION TO TENDER FILE N° /ONIT/MINDDEVEL/NC/NCITB/BIP MINTP / 2026 OF FOR THE CONSTRUCTION WORKS FOR A PERMANENT 6 M REINFORCED CONCRETE BRIDGE IN THE HAUSA QUARTER, INCLUDING THE CONSTRUCTION OF A 2 M x 2 M BOX CULVERT ALONG THE BAMUNKA-NDOP ROAD SECTION; CONSTRUCTION WORKS FOR A PERMANENT 7 M LINEAR REINFORCED CONCRETE BRIDGE OVER THE UPPER KAKE RIVER IN BAMUNKA VILLAGE, ALONG THE BAMUNKA-NDOP ROAD; AND CONSTRUCTION WORKS FOR A PERMANENT 8 M LINEAR REINFORCED CONCRETE BRIDGE OVER THE UPPER MUNJONG RIVER ALONG THE BAMUNKA-NDOP ROAD SECTION IN NDOP MUNICIPALITY, NGOKETUNJIA DIVISION IN NORTH WEST REGION.

We declare as follows:

To have carried out a thorough study of the site taking into consideration all the constraints relative to the execution of job with respect to norms.

To establish our unit price schedules taking into account the difficulties of the site relative to the execution of the works and shall in no condition claim the Delegated Contracting Authority for any increase of unit price.

In Testimony whereof, this present ATTESTATION OF SITE VISIT is established and issued to serve the purpose it deserves.

Done at ___ on the ___

THE DIRECTOR

ANNEX 8: SITE VISIT REPORT

Name of Project.....

Name of Enterprise

CONTEXTE OF THE PROJECT

GEOGRAPHICAL SITUATION

STATE OF THE SITE

PHOTOGRAPHS OF THE SITE (access to the site, existing structures of the school, Sign post of the school,
Photos of the Engineer of the enterprise in front of the school building etc.)

Date.....

Name of Enterprise:

Stamp and signature of enterprise

Document No. 12:

Preliminary Studies

[To be systematically filled by the Project Owner based on the nature of services to be executed and according to the specifications of Point 5.a of Circular No. 003/CAB/PM of 18 April 2008 relating to the respect of rules governing the award, execution and control of public contracts]

Note on preliminary studies

In accordance with the Public Contracts Code, the Project Owner or Delegated Project Owner must, prior to commencing the procedure to award contracts or refer to the competent Tenders Board, ensure that draft tender files are prepared based on preliminary studies.

These studies must be required during the examination of the Tender File (TF) by the Tenders Board.

The Project Owner is bound to fill the questionnaire in annex 1 accompanied by justifications of the said studies.

Annex No. 7: Justification of preliminary studies

Attach the preliminary studies.

Indicate

The date studies were carried out;

The name of the public or private Project Manager

References of the contract, if Private Manager carried it out;

If maintenance works

Description of the studies;

Attach the outline of the itinerary bringing out readings of degradations as well as the approved programming documents.

Rehabilitation or new works

Are quantities in the quotations the same as those of the studies?

Description of studies: Draft Preliminary Study, Detailed Preliminary Study;

Attach the said studies.

N.B. For services of less scope, the Project Owner may furnish a justification of calculation of quantities of the tender file.

The chairperson of the Tenders Board may, before taking a decision, seek expert advice on the quality of the studies.

Document No. 13:

**List of banking establishments and financial
bodies authorised to issue bonds for public
contracts**



**LISTE DES BANQUES ET DES COMPAGNIES D'ASSURANCES AGREES ET HABILITEES A
EMETTRE DES CAUTIONS DANS LE CADRE DES MARCHES PUBLICS EN 2018**

I) BANQUES

1. Afriland First Bank (FIRST BANK), B.P. 11 834, Yaoundé ;
2. Banque Atlantique Cameroun (BACM), B.P. 2 933, Douala ;
3. Banque Camerounaise des Petites et Moyennes Entreprises (BC-PME), B.P. 12 962, Yaoundé ;
4. Banque Gabonaise pour le Financement International (BGFIBANK), B.P. 600, Douala ;
5. Banque Internationale du Cameroun pour l'Epargne et le Crédit (BICEC), B.P. 1 925, Douala ;
6. Bank Of Africa Cameroun (BOA Cameroun), B.P. 4 593, Douala ;
7. Citibank Cameroun (CITIGROUP), B.P. 4 571, Douala ;
8. Commercial Bank-Cameroun (CBC), B.P. 4 004, Douala ;
9. Ecobank Cameroun (ECOBANK), B.P. 582, Douala ;
10. National Financial Credit-Bank (NFC-Bank), B.P. 6 578, Yaoundé ;
11. Société Commerciale de Banques-Cameroun (SCB-Cameroun), B.P. 300, Douala ;
12. Société Générale Cameroun (SGC), B.P. 4 042, Douala ;
13. Standard Chartered Bank Cameroon (SCBC), B.P. 1 784, Douala ;
14. Union Bank of Cameroon (UBC), B.P. 15 569, Douala ;
15. United Bank for Africa (UBA), B.P. 2 088, Douala.

II) COMPAGNIES D'ASSURANCES

16. Activa Assurances, B.P. 12 970, Douala ;
17. Aréa Assurances S.A., B.P. 1 531, Douala ;
18. Atlantique Assurances S.A., B.P. 2933, Douala ;
19. Beneficial General Insurance S.A., B.P.2328, Douala ;
20. Chanas Assurances S.A., B.P. 109, Douala ;
21. CPA S.A., B.P. 54, Douala ;
22. Nsia Assurances S.A., B.P. 2 759, Douala ;
23. Pro Assur S.A., B.P. 5963, Douala ;
24. SAAR S.A., B.P. 1 011, Douala ;
25. Saham Assurances S.A., B.P 11 315, Douala ;
26. Zenithe Insurance S.A., B.P. 1 540, Douala.-

Fait à Yaoundé, le 26 FEV 2018

LE MINISTRE DES FINANCES
The Minister
MINISTRE OF FINANCE
MINISTRE DE FINANCES
ALAMINE OUSMANE MEY

PLANS

QUARTIER HAUSA

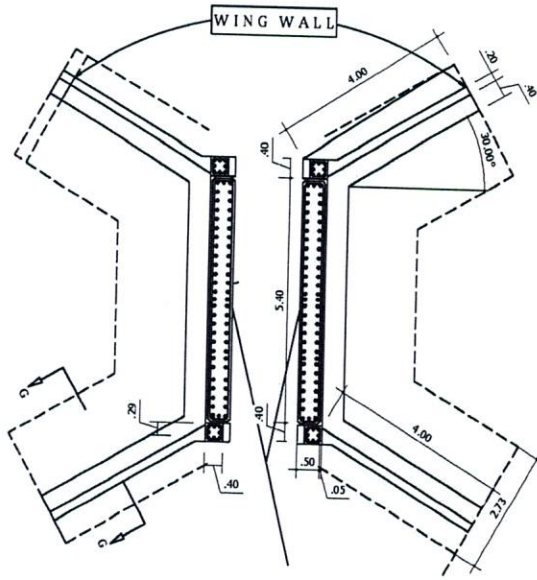

ABUTMENT AND WING WALL

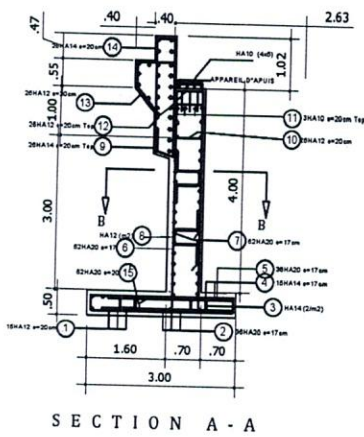
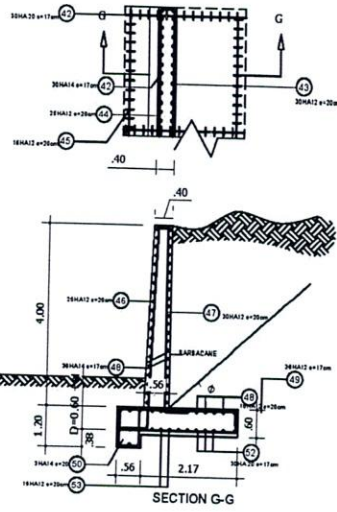

SECTION A - A

DETAILS ON ABUTMENT (2)

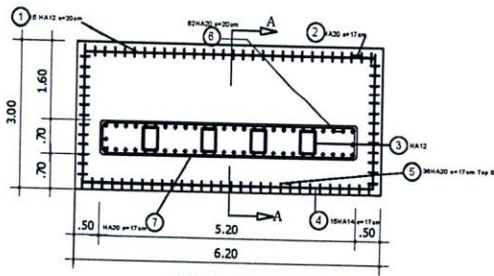

SECTION B - B

Pos	Steel	Code	sketch	Pos	Steel	Code	Sketch
1	15HA12	l=6.30	00	7	25HA20	l=5.80	00
2	28HA20	l=4.10	00	8	HA12	l=1.60	00
4	15HA14	l=6.30	00	9	28HA14	l=2.30	00
5	28HA20	l=4.10	00	10	25HA12	l=3.76	00
6	25HA20	l=4.80	00	11	3HA10	l=5.80	00
8	HA12	l=1.65	00	12	28HA12	l=4.80	00
13	25HA12	l=2.05	00	14	28HA12	l=4.90	00
15	25HA20	l=2.05	00				

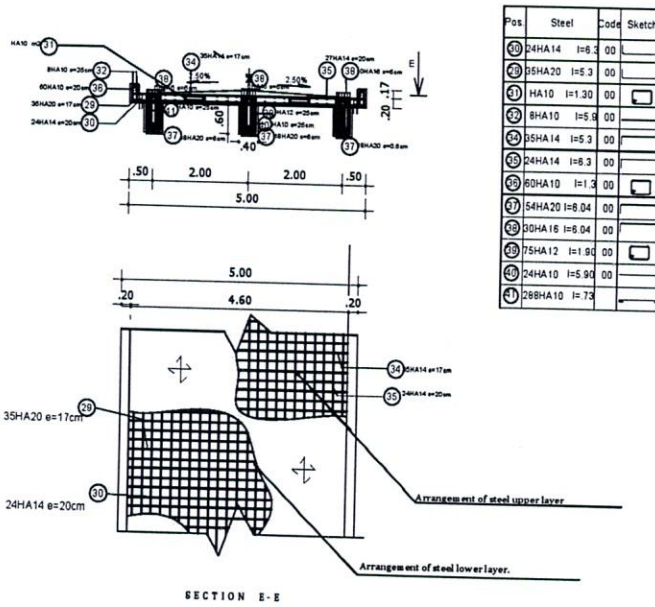

DETAILS ON DECK SLAB

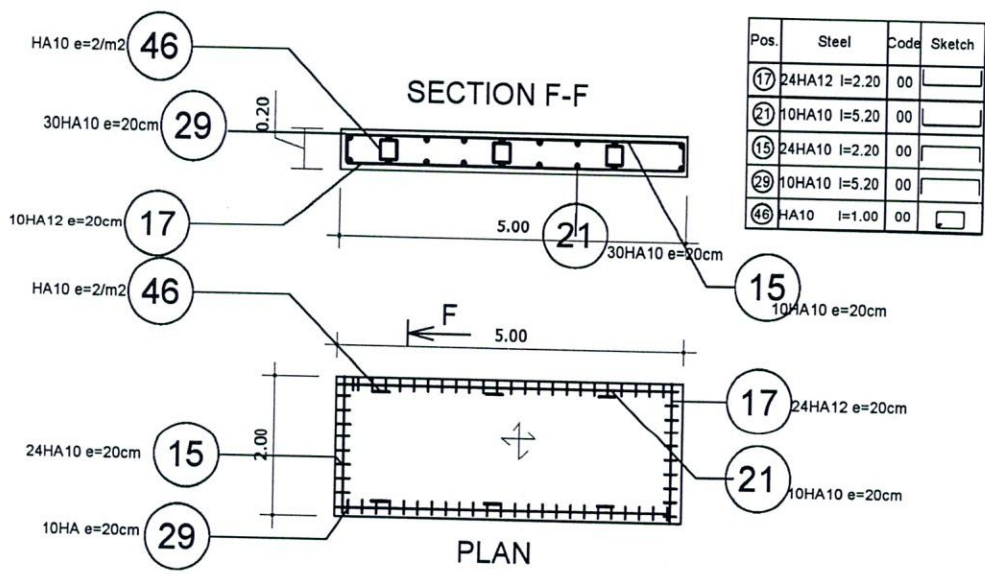

DETAIL C (DALLE DE TRANSITION) (2)

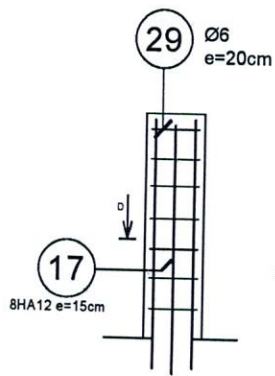

ELEVATION

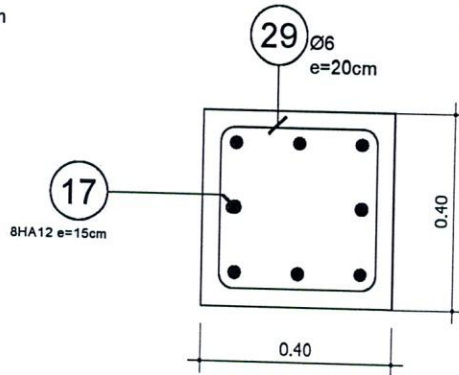

SECTION D-D

Pos.	Steel	Code	Sketch
17	8HA12 l=2.00	00	
29	Ø6 l=1.30	31	

SIGNALIZATION COLUMN 0.40X0.40 OF THE BRIDGE (4)

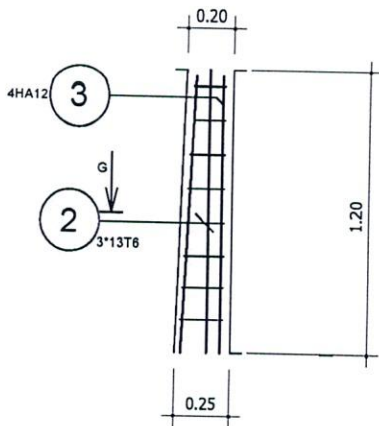

SECTION G-G

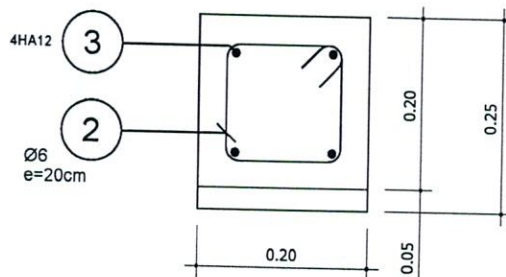

Column of height 1.20m guard rail

Pos.	Steel	Code	Sketch
3	4HA12 l=1.65	00	
2	Ø6 l=1.43	31	

LONGUEUR DE SCELLEMENT

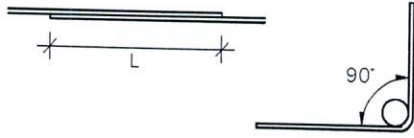

Ø	L
8mm	40cm
10mm	40cm
12mm	50cm
14mm	60cm
16mm	70cm
20mm	125cm

DETAIL CROCHET

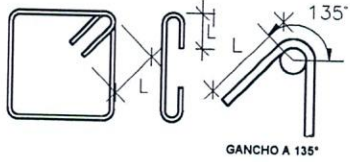

Ø	L	Rmin
6	10cm	1.5cm.
10	15cm	2.0cm.

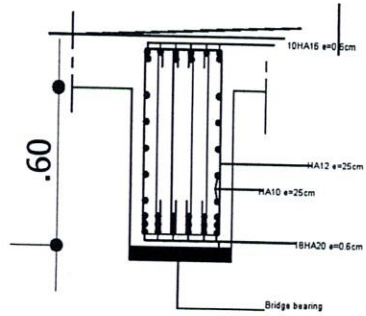

DETAIL MAIN BEAM

UPPER KAKE

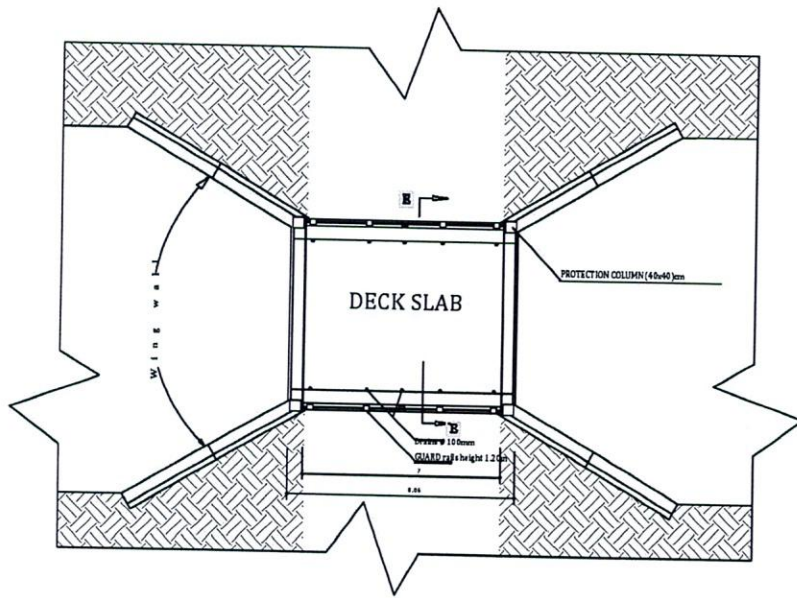

PLAN

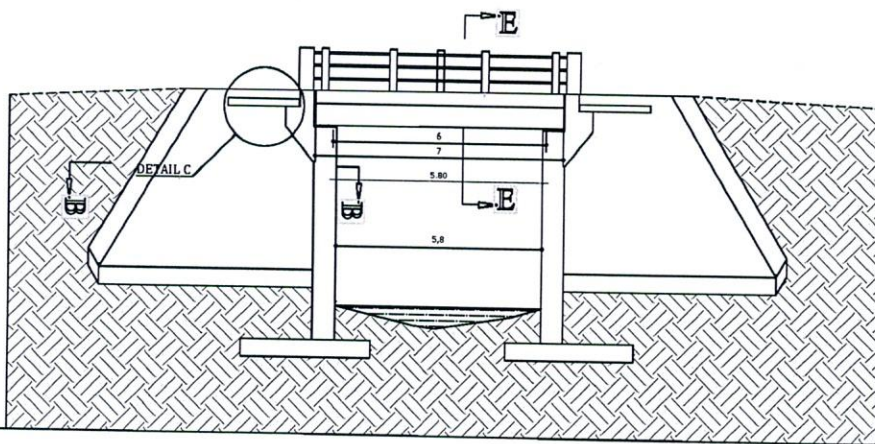

ELEVATION

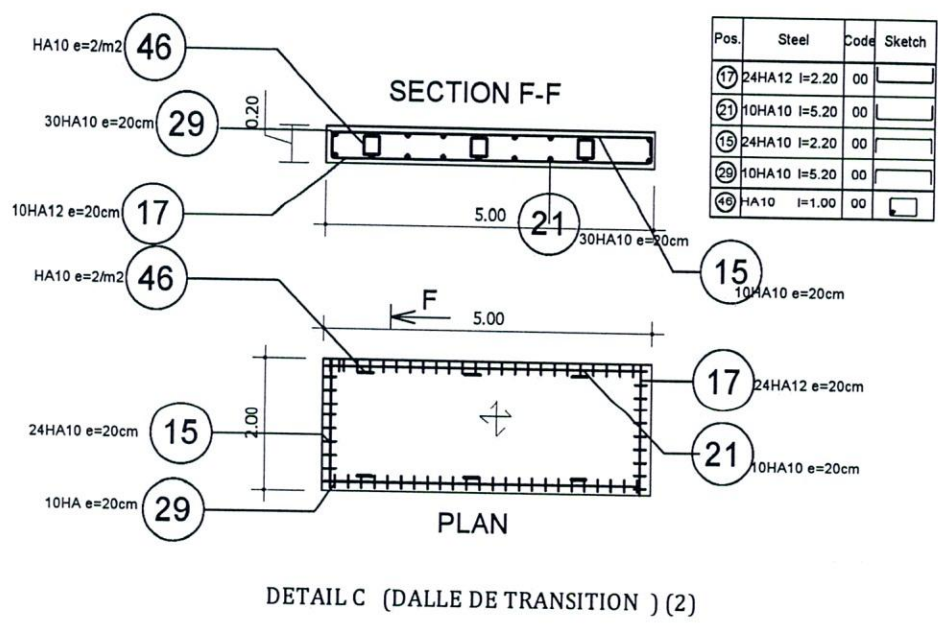
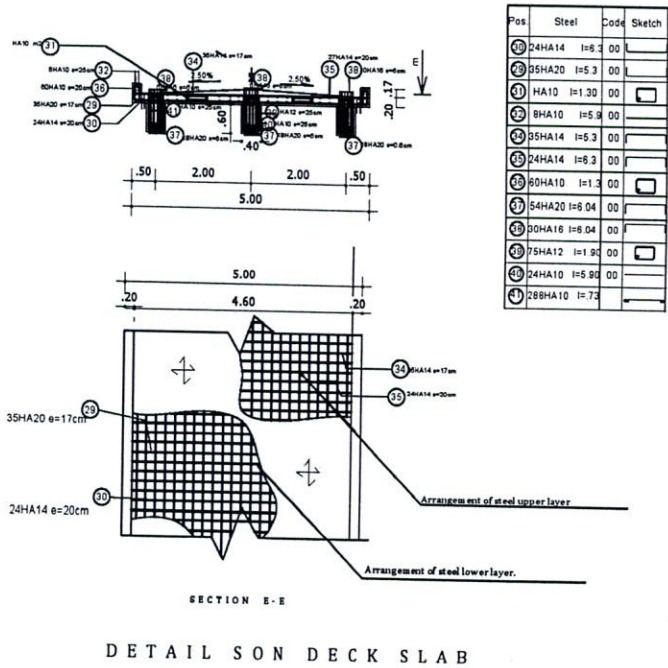

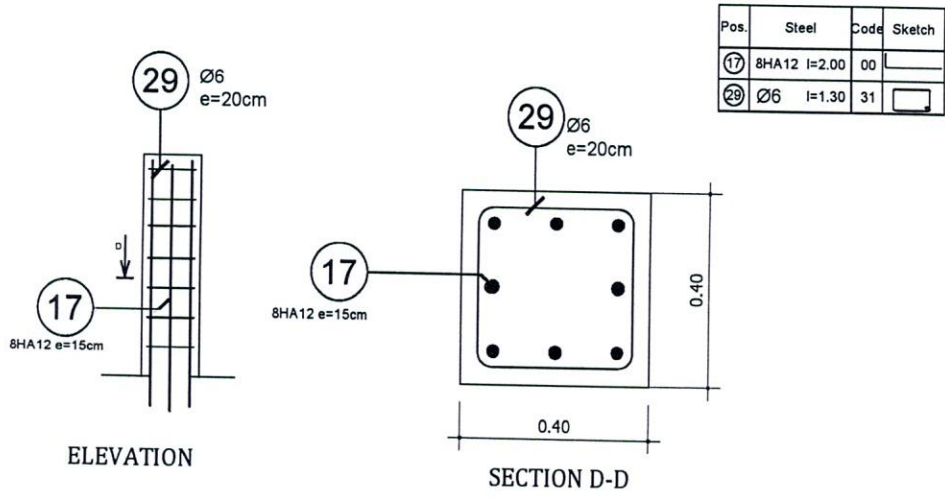

SIGNALIZATION COLUMN 0.40X0.40 OF THE BRIDGE (4)

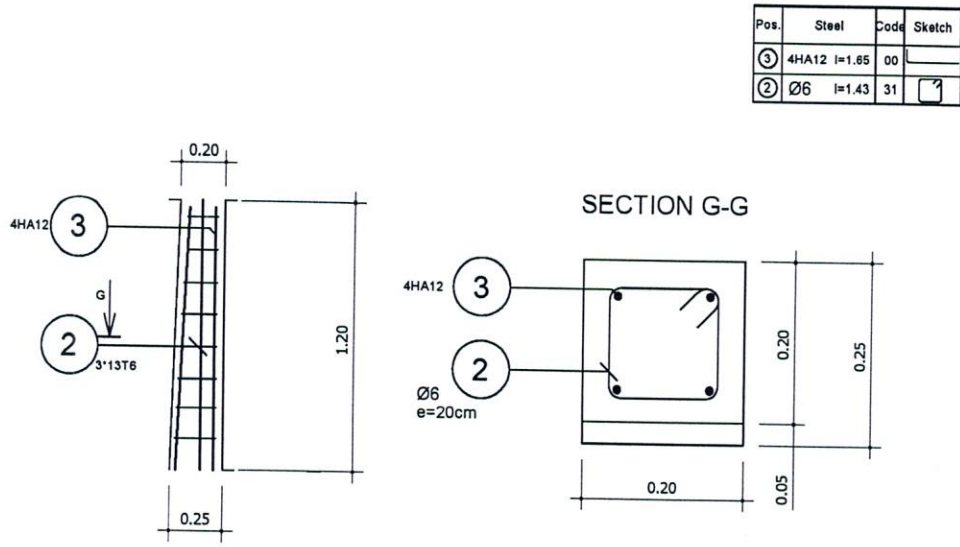

Column of height 1.20m guard rail

LONGUEUR DE SCELEMENT

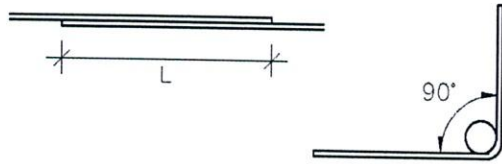

Ø	L
8mm	40cm
10mm	40cm
12mm	50cm
14mm	60cm
16mm	70cm
20mm	125cm

DETAIL CROCHET

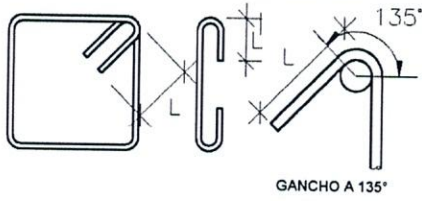

Ø	L	Rmin
6	10cm	1.5cm.
10	15cm	2.0cm.

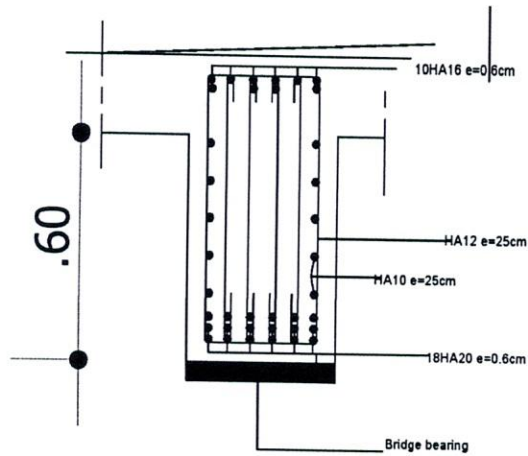

DETAIL MAIN BEAM

UPPER MUNJONG

Bridge of 8m span and 4m height

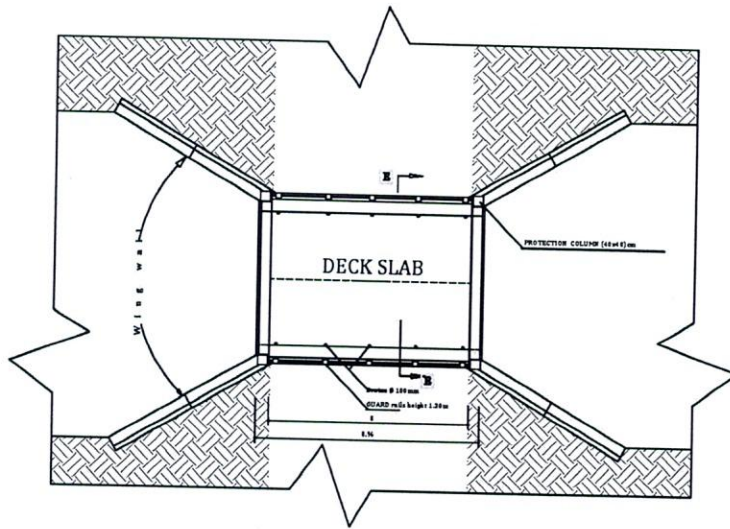

PLAN

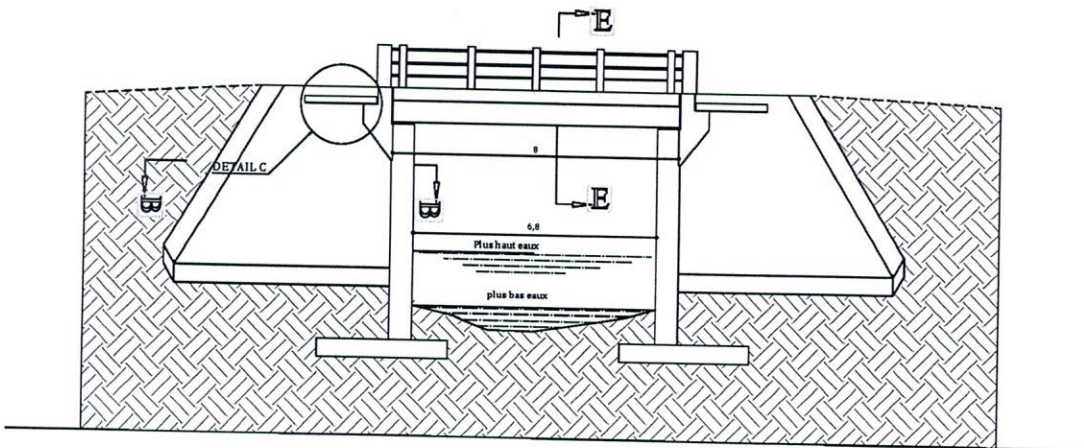

ELEVATION

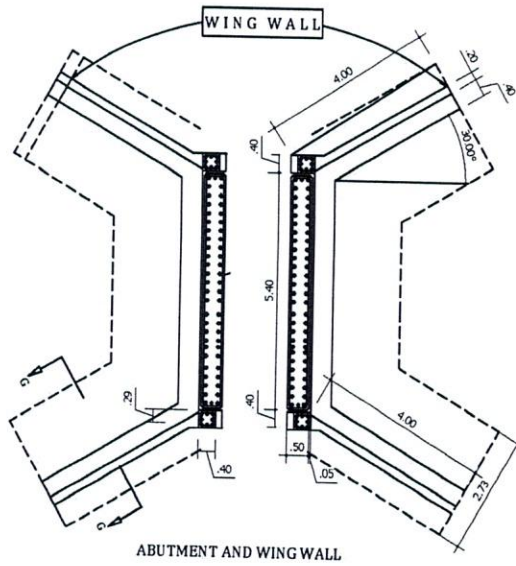

ABUTMENT AND WING WALL

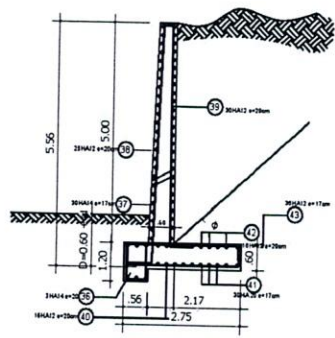
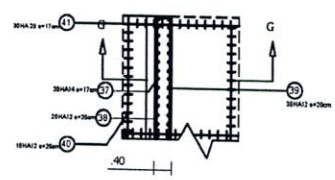

SECTION G-G

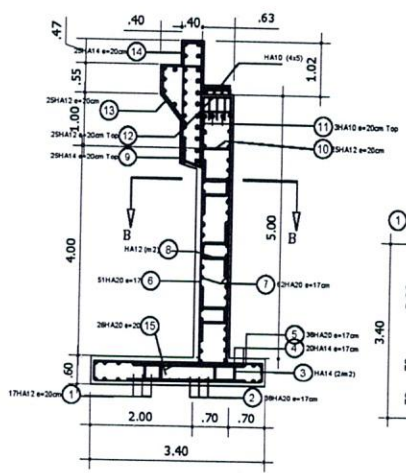

SECTION A - A

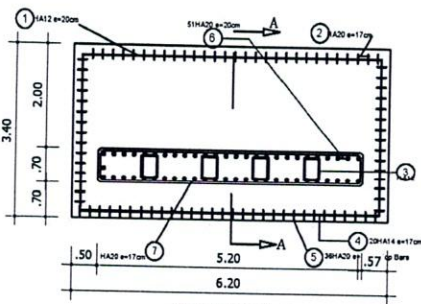

SECTION B-B

Pos	Steel	Code	Sketch	Pos	Steel	Code	Sketch
1	17HA12	l=6.30		7	20HA20	l=5.80	
2	20HA20	l=4.10		8	HA12	l=1.60	
3	20HA14	l=6.30		9	25HA14	l=2.30	
4	20HA20	l=4.10		10	25HA12	l=3.60	
5	18HA12	l=4.10		11	3HA10	l=5.80	
6	HA12	l=1.65		12	25HA12	l=4.80	
13	25HA12	l=2.05		14	25HA12	l=4.90	
15	28HA20	l=2.05					

DETAILS ON ABUTMENT (2)

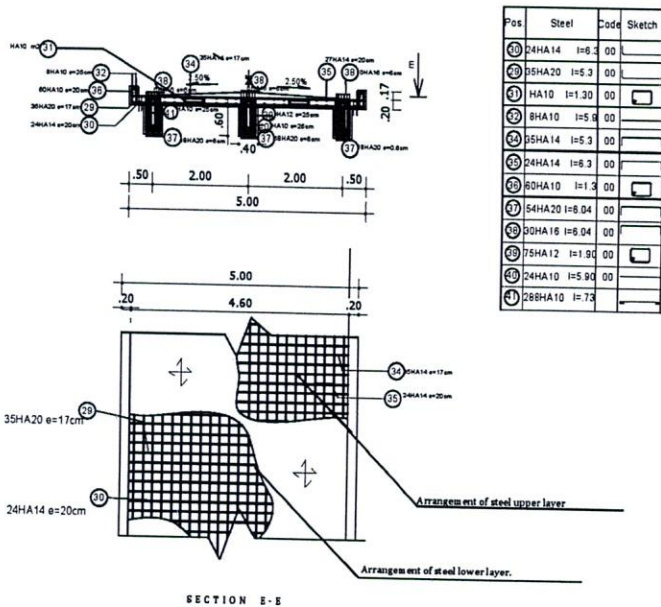

DETAILS ON DECK SLAB

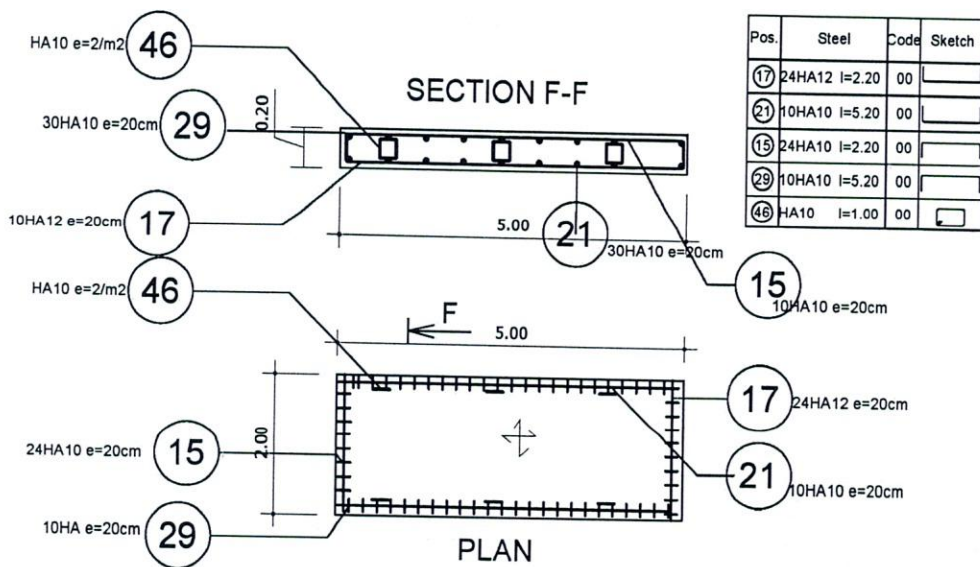

DETAIL C (DALLE DE TRANSITION) (2)

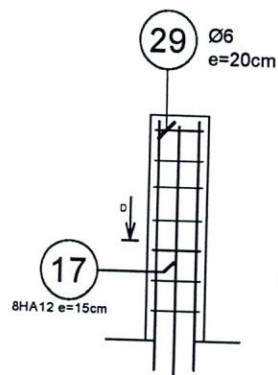

ELEVATION

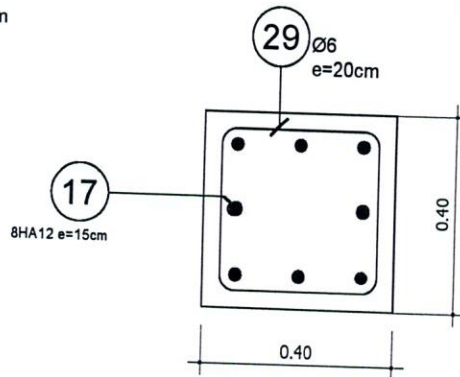

SECTION D-D

Pos.	Steel	Code	Sketch
17	8HA12 l=2.00	00	
29	Ø6 l=1.30	31	

SIGNALIZATION COLUMN 0.40X0.40 OF THE BRIDGE (4)

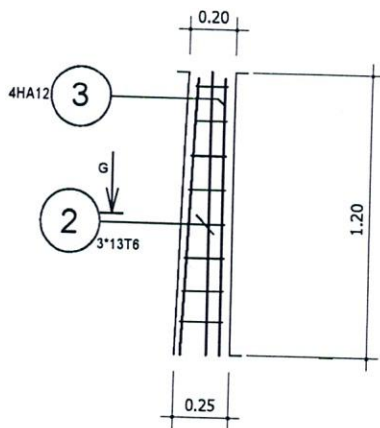

SECTION G-G

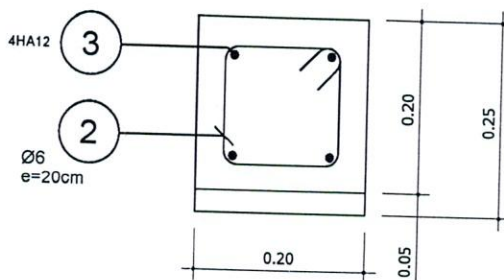

Column of height 1.20m guard rail

Pos.	Steel	Code	Sketch
3	4HA12 l=1.65	00	
2	Ø6 l=1.43	31	

LONGUEUR DE SCELLEMENT

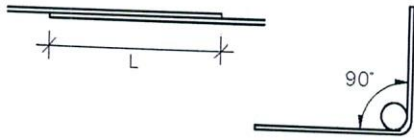

Ø	L
8mm	40cm
10mm	40cm
12mm	50cm
14mm	60cm
16mm	70cm
20mm	125cm

DETAIL CROCHET

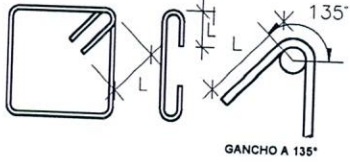

Ø	L	Rmin
6	10cm	1.5cm.
10	15cm	2.0cm.

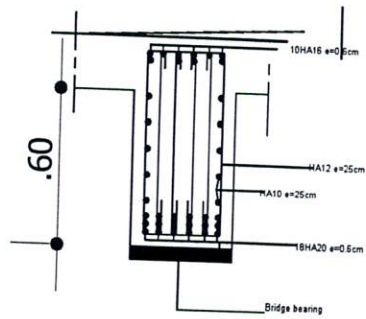

DETAIL MAIN BEAM